

A Guide to Forklift Operator Training

Bobby R. Davis
Series Editor



N.C. Department of Labor
Division of Occupational Safety and Health
1101 Mail Service Center
Raleigh, NC 27699-1101

Cherie K. Berry
Commissioner of Labor

**N.C. Department of Labor
Occupational Safety and Health Program**

Cherie K. Berry
Commissioner of Labor
OSHA State Plan Designee

Allen McNeely
Deputy Commissioner for Safety and Health

Kevin Beauregard
Assistant Deputy Commissioner for Safety and Health

Acknowledgments

A Guide to Forklift Operator Training was originally prepared by Thomas O'Connell (supervisor, OSH Compliance) and Douglas Wall (former OSHNC employee). This edition was revised and updated as of January 2004 by series editor to include information printed by U.S. Department of Labor OSHA at its Web site (www.osha.gov) to address safety and health topics of powered industrial trucks.

This guide is intended to be consistent with all existing OSHA standards; therefore, if an area is considered by the reader to be inconsistent with a standard, then the OSHA standard should be followed.

To obtain additional copies of this book, or if you have questions about N.C. occupational safety and health standards or rules, please contact:

**N.C. Department of Labor
Bureau of Education, Training and Technical Assistance
1101 Mail Service Center
Raleigh, NC 27699-1101**

Phone: (919) 807-2875 or 1-800-NC-LABOR (1-800-625-2267)

Additional sources of information are listed on the inside back cover of this book.

The projected cost of the OSHNC program for federal fiscal year 2003–2004 is \$13,190,191. Federal funding provides approximately 39 percent (\$5,162,000) of this total.

Printed 7/04



Contents

	Page
Foreword	v
Purpose of the Guide	vi
Powered Industrial Truck Operator Training Standard Summary	vii
Frequently Asked Questions About the Training Regulation	1
Developing a Training Program for Powered Industrial Truck (PIT) Operators	5
Sample Lesson Plan	6
Training Examples.	8
General Operating Procedures for Forklifts	10
• Maintenance	12
• Refueling.	12
• Changing and Charging Storage Batteries.	12
• Starting a Forklift	13
• Traveling.	13
• Loading	13
• Transporting Loads and Maneuvering	14
• Unloading	14
• Forklift Classifications and Where Forklifts May Be Operated	14
• Lighting	15
• Noxious Gases and Fumes	15
• Hazardous Materials and Areas for Hazardous Material	15
• Safety Tips	15
• Stability of Powered Industrial Trucks	16
Sample Daily Checklists for Powered Industrial Trucks	20
• Sample Generic Checklists for PITs	20
• Sample Daily Inspection Checklists	21
• Electric Forklift Truck	21
• Propane Forklift Truck	22
• Yard Forklift Truck	23
• Electric Transtacker	23
• Riding Grip Tow	24
• Stand-up Riding Tow Tractor	24
• Walking Pallet Truck	24
• Walking Transtacker.	24
• Indoor Propane Tow Tractor	25
• Industrial Tractors	25
• Reach Truck	26
• Order Picker	26
Sample Performance Test for Forklift Operators	27
CFR 1910.178, Powered Industrial Trucks	28
Summary Table on Use of Industrial Trucks in Various Locations	30
Safety and Health Topics: Powered Industrial Trucks.	36

Foreword

The powered industrial truck, commonly referred to as the forklift, is an essential piece of equipment in North Carolina factories and plants. As important and productive as forklifts are, they also can be dangerous if not properly used. Of the 998,671 trucks in use in our country, it is estimated that there will be 1.4 accidents per vehicle over each vehicle's eight-year average lifetime.

A Guide to Forklift Operator Training compiles the steps necessary for safe forklift operation. To those learning how to operate this vehicle, it offers tips for protecting themselves and others who may work near the truck.

In North Carolina, the N.C. Department of Labor enforces the federal Occupational Safety and Health Act. NCDOL offers many educational programs to the public and produces publications to help inform people about their rights and responsibilities regarding occupational safety and health.

When reading this guide, please remember the NCDOL mission is greater than just regulatory enforcement. An equally important goal is to help citizens find ways to create safe workplaces. Everyone profits when managers and employees work together for safety. This booklet, like the other educational materials produced by the N.C. Department of Labor, can help.

Cherie K. Berry
Commissioner of Labor

Purpose of the Guide

NCDOL industry guides are designed to assist you in complying with the occupational safety and health rules and regulations of North Carolina. This book is aimed at alerting you to the rules concerning powered industrial truck training. It is designed to be used along with the operator manuals for the specific types of powered industrial trucks that you operate to develop a more complete operator training program. It should help you understand your responsibility to provide such training, while at the same time offering sample training outlines to assist you in meeting the minimum requirements of the standard. If there is any confusion between the regulation and this guide, the regulation should be followed.

Powered Industrial Truck Operator Training Standard Summary

The Occupational Safety and Health Administration (OSHA) clarified the training requirements for powered industrial truck operator training. It was added to *Title 29 Code of Federal Regulations Part 1910.178*. The clarification was issued to improve the training of operators. By improving the regulations, it is hoped that there will be a reduction in the number of injuries and deaths that occur as a result of inadequate operator training. The changes apply to both general industry and the construction industry.

The training program should be based upon:

1. The operator's prior knowledge and skill
2. The types of powered industrial trucks the operator will operate in the workplace
3. The hazards present in the workplace
4. The operator's demonstrated ability to operate a powered industrial truck safely

Refresher training may be required if:

1. The operator is involved in an accident or a near-miss incident
2. The operator has been observed operating the vehicle in an unsafe manner
3. The operator has been determined during an evaluation to need additional training
4. There are changes in the workplace that could affect safe operation of the truck
5. The operator is assigned to operate a different type of truck

Evaluations of each operator's performance are required as part of the initial and refresher training and at least once every three years.

Class I—Electric Motor Rider Trucks

- Counterbalanced rider type, stand-up
- Three-wheel electric trucks, sit-down
- Counterbalanced rider type, cushion tires, sit-down (high and low platform)
- Counterbalanced rider type, pneumatic tire, sit-down (high and low platform)

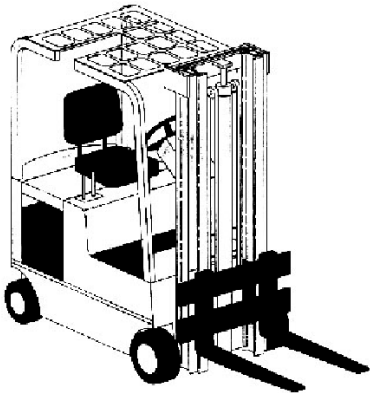

Sit-down Rider Type—Electric



Counterbalanced Stand-up Rider Type

Class II—Electric Motor Narrow Aisle Trucks

- High lift straddle
- Order picker
- Reach type outrigger
- Side loaders, turret trucks, swing mast and convertible turret/stock pickers
- Low lift pallet and platform (rider)

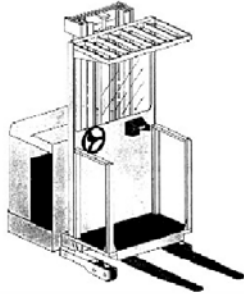

Order Picker

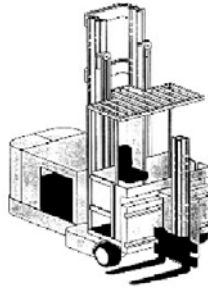

Turret Truck

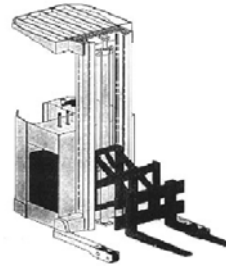

*Reach Type
Outrigger*



Rider Reach Truck



Order Picker

Class III—Electric Motor Hand or Hand/Rider Trucks

- Low lift platform
- Low lift walkie pallet
- Reach type outrigger
- High lift straddle
- High lift counterbalanced
- Low lift walkie/rider pallet

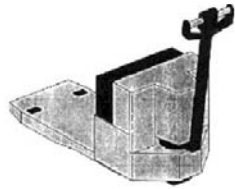

Low Lift Platform

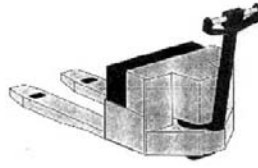

Low Lift Walkie Pallet

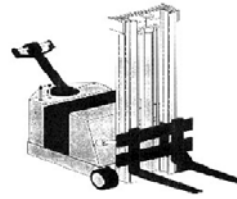

High Lift Counterbalanced



Walkie Powered Pallet Truck



Walkie/Rider Powered Pallet Truck

Class IV—Internal Combustion Engine Trucks—Cushion (Solid) Tires

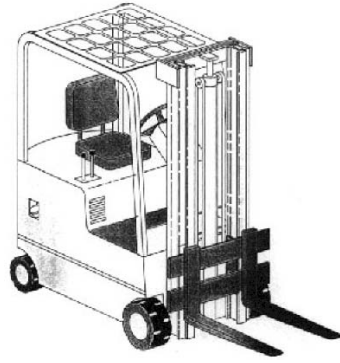

*Fork Counterbalanced
(Cushion/Solid Tires)*



Sit-down Rider Fork—LPG

Class V—Internal Combustion Engine Trucks—Pneumatic Tires

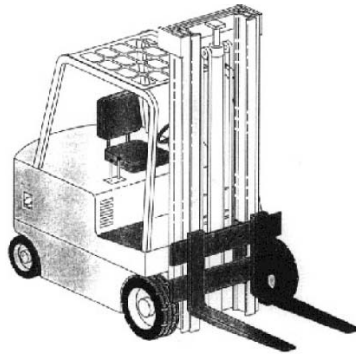

*Fork Counterbalanced
(Pneumatic Tires)*



*Sit-down Rider—Gas—
Pneumatic Tires*

Class VI—Electric and Internal Combustion Engine Tractors

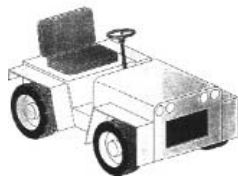

Sit-down Rider

Class VII—Rough Terrain Forklift Trucks



Straight Mast

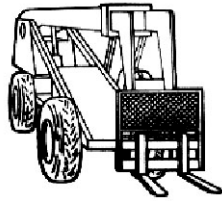

Extended-Reach



Frequently Asked Questions About the Training Regulation

What is a powered industrial truck?

The American Society of Mechanical Engineers (ASME) defines a powered industrial truck as a mobile power-propelled truck used to carry, push, pull, lift, stack or tier materials. Powered industrial trucks, often called forklifts or lift trucks, can be ridden or controlled by a walking operator.

Powered industrial trucks are classified by the manufacturers according to their individual characteristics. There are seven classes of powered industrial trucks:

- Class I— Electric Motor, Sit-down Rider, Counter-Balanced Trucks (Solid and Pneumatic Tires)
- Class II— Electric Motor Narrow Aisle Trucks (Solid Tire)
- Class III— Electric Motor Hand Truck or Hand/Rider Trucks (Solid Tires)
- Class IV— Internal Combustion Engine Truck (Solid Tires)
- Class V— Internal Combustion Engine Trucks (Pneumatic Tires)
- Class VI— Electric and Internal Combustion Engine Tractors (Solid and Pneumatic Tires)
- Class VII— Rough Terrain Forklift Trucks (Pneumatic Tires).

According to 1910.178(a)(1) a powered industrial truck is defined as a fork truck, tractor, platform lift truck, motorized hand truck, and other specialized industrial trucks powered by electric motors or internal combustion engines. Under the OSHA definition, a powered industrial truck does not include compressed air or nonflammable compressed gas-operated industrial trucks, farm vehicles, vehicles intended primarily for earth moving, or over-the-road hauling.

What is the new OSHA powered industrial truck standard?

The new standard requires employers to develop a training program *specific to the type of truck to be driven and the working conditions encountered*. Employers must also evaluate the operator's performance in the workplace and certify that each operator has received the training needed.

Why is this training needed?

Each type of powered industrial truck has its own unique characteristics and some inherent hazards. Powered industrial trucks may operate on almost any surface, from smooth level floors to rocky uneven ground. Different trucks are designed and manufactured to operate in different work environments. Powered industrial trucks can be equipped with or can be modified to accept attachments to fit the intended load. They can be used to lift personnel. They can be used in hazardous locations. The hazards commonly associated with powered industrial trucks vary for different vehicle types, makes and models. Each type of truck has different operating hazards. The methods and means to prevent an accident and to protect employees from injury vary; therefore, site-specific training, in typical working conditions, is required to address all possible scenarios.

What hazards does this regulation address?

The workplace where these trucks operate include hazards such as rough, uneven or sloped surfaces; unusual loads; hazardous areas; narrow aisles; blind spots; intersections; and pedestrian traffic or employees working close to the path of travel. Operating problems of excessive speed, poor loading and carrying unauthorized passengers, in addition to poor truck maintenance, have the potential to cause accidents.

Fatal accidents have occurred due to forklift turnover, striking something and running off the dock. Workers have died when pinned between objects, struck by material, struck by forklifts, falling from the forklift and during forklift repair.

Who must implement the regulation?

The employer must ensure that each powered industrial truck operator is competent to operate a powered industrial truck.

What North Carolina regulations are affected by this change?

29 CFR Part 1910.178(l) Occupational Safety and Health for General Industry

29 CFR Part 1926.602(d) Occupational Safety and Health for Construction

Who is covered by this regulation?

In general, employers who have employees operating powered industrial trucks are required to meet the training requirements. Employers who have employees who must work around them must be knowledgeable of the regulation and ensure that their employees are not exposed to hazards from the operation of these trucks. Unique to the construction industry is the general contractor's requirement for maintaining a safe workplace at the site. Within this duty is the general contractor's responsibility of ensuring that its subcontractors are operating the powered industrial trucks on their site in a safe manner.

When do I have to be in compliance?

The effective date of the regulation is March 1, 1999. The employer must be in compliance by Dec. 1, 1999. For an employee hired before Dec. 1, 1999, the employer must be in compliance with the certification and training requirements by Dec. 1, 1999. If an employee is hired after Dec. 1, 1999, then the training and evaluation must be completed before the employee is assigned to operate a powered industrial truck.

Who must be trained?

Only powered industrial truck operators and trainees require training. "Potential" operators are not covered. However, an employee who has other duties, but sometimes operates a powered industrial truck, also requires training.

What types of training format can be used?

The training must be a combination of formal (lecture, video, etc.) and practical (demonstration and practical exercises) and must include an evaluation of operator performance in the workplace. Truck-related and workplace-related topics must be included, along with the requirements of the OSHA standard. The specific training topics are listed in the standard.

What subjects must be covered?

Powered industrial truck operator trainees must be trained in the following topics unless the employer can demonstrate that some of the topics are not needed for safe operation.

(I) Truck-related topics.

- (A) All operating instructions, warnings and precautions for the types of truck the operator will be authorized to operate;
- (B) Similarities to and differences from the automobile;
- (C) Controls and instrumentation: location, what they do, and how they work;
- (D) Power plant operation and maintenance;
- (E) Steering and maneuvering;
- (F) Visibility (including restrictions due to loading);
- (G) Fork and attachment adaptation, operation and limitations of their utilization;
- (H) Vehicle capacity;
- (I) Vehicle stability;
- (J) Vehicle inspection and maintenance;
- (K) Refueling or charging, recharging batteries;
- (L) Operating limitations; and

(M) Any other operating instruction, warning or precaution listed in the operator's manual for the type vehicle that the employee is being trained to operate.

(II) Workplace-related topics.

(A) Surface conditions where the vehicle will be operated;

(B) Composition of probable loads and load stability;

(C) Load manipulation, stacking and unstacking;

(D) Pedestrian traffic;

(E) Narrow aisles and other restricted places of operation;

(F) Operating in hazardous classified locations;

(G) Operating the truck on ramps and other sloped surfaces that could affect the stability of the vehicle;

(H) Operating the vehicle in closed environments and other areas where insufficient ventilation could cause a buildup of carbon monoxide or diesel exhaust; and

(I) Other unique or potentially hazardous environmental conditions that exist or may exist in the workplace.

Does the employer have to continually train every operator after the operator has received initial training?

Before an employee is permitted to operate a powered industrial truck, except for training purposes, the employee must successfully complete the required training including an evaluation. When an operator has received his or her initial operator training and moves to a new employer, that new employer can evaluate the employee's previous training for adequacy and appropriateness. The employer then can determine if the employee can do the job safely. Duplicative training would not be required in this situation; however, it is recommended that the employer carefully document its evaluation (or that of the designated trainer) of the new employee's ability to safely operate the company's powered industrial trucks. The employer may only need to provide additional training on site-specific or truck-specific matters.

Who can conduct the training?

A designated person must conduct all training. OSHA defines a designated person as one who has the requisite knowledge, training and experience to train powered industrial operators and judge their competency. OSHA does not specify that the employer, a supervisor or any other particular person must conduct the training, but only a person who is qualified to do so. The training and evaluation does not have to be conducted by a single individual, but can be done by several persons, provided each one is qualified.

How long will it take?

Depending on a number of factors, including the site, equipment and number of personnel to be trained, it is estimated that the initial training will take approximately 5.5 hours.

What kind of operator evaluation is required?

This is a performance-oriented standard. The regulation lets the employer determine when the employee has successfully completed the training. The bottom line is that successful completion requires the trainee to perform all required operations safely.

What kind of certification is required?

The employer is certifying that each operator:

1. Has received the training
2. Has been evaluated
3. Has demonstrated competency in the performance of the operator's duties

The actual certification needs to include:

1. The name of the trainee
2. The date of training
3. The signature of the person performing the training and evaluation

Is there a requirement for retraining?

Sufficient evaluation and remedial training must be conducted so that the employee retains and uses the knowledge, skills and ability needed to operate the powered industrial truck safely. Refresher training is required when:

1. There has been an unsafe operation
2. An accident or near miss occurs
3. An evaluation indicates that the operator is not capable of performing the assigned duties
4. A new type of truck has been introduced into the workplace

There is no fixed period for refresher training and evaluation; instead, such training is triggered when an incident or workplace change indicates that it is necessary. The employer is required to evaluate the operator's proficiency every three years.

How does the employer avoid duplicative training?

Employers may forgo those portions of the required training that operators have previously received. If an operator is already trained in certain aspects of powered industrial trucks operation, knows the necessary information, has been evaluated, and has proven to be competent to perform the duties of an operator, the employer is not required to repeat that operator's training.

How does the employer evaluate the operator's prior training?

The employer may consider:

1. The type of equipment the operator has operated
2. How much experience the operator has had on that type of equipment
3. How recently this experience was gained
4. The types of environment the operator has worked

The employer may, but is not required to, use written documentation of the earlier training to determine whether an operator has been properly trained. The employer or another person with requisite knowledge, skills and experience to perform evaluations may simply evaluate the operator's competency. The employer can determine from this information whether the experience is recent and thorough, and whether the operator has demonstrated sufficient competence in operating the powered industrial truck to forgo any or some of the initial training. Some training involving the site-specific factors of the new operator's workplace is always likely to be necessary.

Does every subject have to be taught?

Training must address topics specific to the employer's workplace. If a particular topic is not relevant to the types of vehicles or the employer's workplace, then it may not need to be addressed.

Information learned from near misses that have occurred in the employer's workplace must be part of the training. Operator training must emphasize two points regarding potential accidents: (1) actions that increase the potential for an accident to occur and (2) the actions of employees required to minimize the potential for injury to the operator or to other employees if an accident occurs.

How do I record the training?

The employer must certify that the operators are qualified by training and evaluation to operate the powered industrial truck. Materials used for training must be maintained. However, the requirement for employers to maintain materials and information from outside trainers has been eliminated.

The certification required by the rule provides sufficient written evidence that the training and evaluation required by the standard has occurred. OSHA believes the certification requirements will provide the assurances necessary that the operator has been trained and evaluated.

Where can I get additional information about OSHA and new standards?

For more information, see the inside back cover of this industry guide for sources of information.

Developing a Training Program for Powered Industrial Truck Operators

Before you begin developing your operator-training program, you should become familiar with the OSHA standard for powered industrial trucks and any operator's manual pertinent to the equipment you have in your workplace.

Identify your operators

First, you need to determine the employees that will be required to operate powered industrial trucks in your workplace. If an employee has other duties, but sometimes operates a powered industrial truck, training must be provided.

Identify the types of powered industrial trucks you have in your workplace and those employees who will be required to operate the vehicles

There are many different types of powered industrial trucks. Typically, these types of vehicles are known as forklifts or lift trucks. Some types of trucks are not capable of being ridden by the operator. These are also covered by the OSHA standard and training is required. Some trucks are fitted with attachments purchased from the manufacturer. The use of these attachments may affect the manner in which the truck is handled; therefore training on the use of the attachment would also be required. If your employees will be expected to operate several different types of powered industrial trucks, then training is required on the unique handling characteristics of all the vehicles.

Methods of training

Once you have identified your truck operators and types of trucks you have in your workplace, you should determine the methods of training you will use. Training must consist of a combination of formal instruction and practical training. Using both methods is the only way to ensure that the trainee receives and comprehends the instruction and uses the information to safely operate a powered industrial truck. Note that the formal training need not take place in a classroom. Discussions can consist of the trainer talking to the trainee and explaining the training material, either in the workplace or in another location. The training must, however, include an explanatory element as well as a practical element.

Formal instruction may include lectures, conferences, classroom discussions, demonstrations, and written or oral tests. To enhance the training and make it more understandable to the employee, employers and other trainers may use movies, slides, computers, videotapes and other visual presentations.

Using visual aids has several advantages, including:

1. The employees being trained remain more attentive, thereby increasing the training's effectiveness.
2. The trainer can use visual presentations to ensure that the necessary information is covered during the training.
3. Graphical presentations make better use of the training time by decreasing the need for the instructor to carry on long discussions about the instructional material.
4. Trainees have greater retention of information learned from graphical presentations.

While some employees can learn instructional material while seated in a classroom, other employees may learn best by observing an operation (demonstration) and/or by personally performing an operation (practical exercise). In most cases, a combination of different training methods provides the best training in the least amount of time. Once you have selected the method of training, then the content of the training program must be considered to include all pertinent training items.

Sample Lesson Plan

Powered Industrial Truck (Pit) Operator Training Program Outline*

This PIT operator training program outline has been designed to assist designated, qualified trainers in providing sufficient operator training, as required by the new OSHA powered industrial truck standard.

The entire training program must combine both formal and practical training. Therefore, it is suggested that the trainer stagger classroom time with practical application on a powered industrial truck in a common setting. To keep your student's interest and maximize learning, you may also want to incorporate some "real-world" examples of forklift fatalities, as provided in the next section of this guide.

1. Introduction
 - a. Overview of the program
 - b. Goal of the program: to provide a training program based on the trainee's prior knowledge, the types of vehicles used in the workplace, and the hazards of the workplace.
 - c. Course will utilize video, group discussion and hands-on practice. All operators must obtain the knowledge and skills needed to do their job correctly and safely.
2. Types, features and physics
 - a. Familiarize each operator with the basic types and functions of powered industrial trucks.
 - b. Develop an understanding of the information shown on a data plate.
 - c. Understand the critical truck measurements that affect safety.
 - d. Understand the forces that cause tipovers, and the truck design considerations and safety ratings that help prevent them, including the "stability triangle."
3. Inspecting the vehicle
 - a. Understand the purpose and importance of preoperational checkouts.
 - b. Provide a basic understanding of areas covered during a preoperational checkout.
 - c. Familiarize each operator with a checklist for preoperational checkouts and what to do if a problem is discovered.
4. Driving the truck
 - a. Understand the elements of safe movement of a powered industrial truck.
 - b. Understand the differences between an automobile and a powered industrial truck.
 - c. Recognize the safety hazards associated with operating a powered industrial truck.
5. Load handling
 - a. Understand the elements of load lifting safety.
 - b. Understand the safe operating procedures for raising and lowering loads in aisles.
6. LPG for lift trucks
 - a. Discuss LPG and its properties.
 - b. Understand the elements and procedures of safely refueling internal combustion vehicles.
 - c. Describe tank components: service valve, surge valve, relief valve, etc.
 - d. Discuss related safety issues.
7. Battery and charging
 - a. Understand the elements and procedures of safely changing and charging batteries.
 - b. Discuss filling procedures and maintenance.
 - c. Discuss related safety issues.

*This outline is intended as a resource in implementing a powered industrial truck operator-training program. It is not a substitute for any standards issued by the U.S. Department of Labor's Occupational Safety and Health Administration (OSHA). OSHA's Office of Training and Education wishes to acknowledge Material Handling Services for contributing some of the information used in this outline. This acknowledgment does not imply endorsement by the U.S. Department of Labor.

8. Safety concerns
 - a. Review/reinforce potential of serious injury
 - b. Review/reinforce safety procedures in your facility.
9. Specific truck and workplace training/hands-on
 - a. Review features of specific PITs to be operated.
 - b. Review operating procedures of specific PITs to be operated.
 - c. Review safety concerns of specific PITs to be operated.
 - d. Review workplace conditions and safety concerns of areas where PITs will be operated.
 - e. Learn/practice actual operation of specific PITs to be operated and specific workplace conditions where PITs will be operated.
 - f. Demonstrate proficiency performing the powered industrial truck operator duties specific to the trainee's position and workplace conditions.
10. Certification of completion of the course

Components of a Forklift Truck

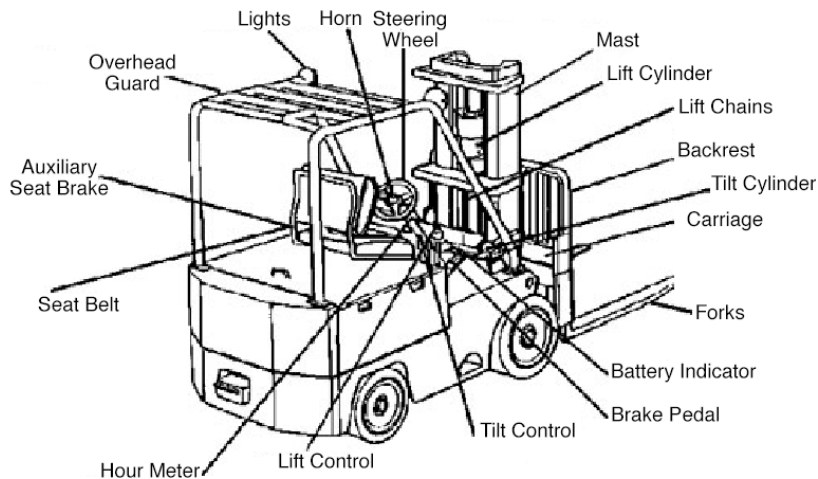

Training Examples

These real-world examples are provided for use as a training tool and are composed of actual summaries of selected forklift fatalities investigated by OSHA. It is hoped that the lessons learned by reviewing the details of these accidents will help prevent future forklift fatalities.

Selected Fatalities Investigated in 1998

- *Forklift tipover:* While an employee was operating a forklift, the forklift tipped over while the operator was apparently making a sharp turn at excessive speed. No seat belt was installed. When employee fell from the seat, he was crushed by the rollover bar.
- *Fall from platform on forklift:* The victim (employee #1) was found pinned between the mast and the frame of the forklift. Prior to the accident, employee #1 was raised approximately 6 feet high by the forklift operator while the employee was standing on a pallet that was not secured to the frame of the forklift. The operator left the forklift unattended while the employee was on the pallet pouring spice into a mixing tank.
- *Crushed by forklift:* Victim was driving a stand-up forklift into a tractor trailer to start unloading when the truck driver pulled away from the dock. The forklift fell back onto the forklift driver, striking his head and apparently breaking his neck.
- *Struck by forklift:* The employee was given instructions to take the forklift to unload a truck. The employee picked up the forklift located on the premises less than one-half mile from where the accident occurred. Traveling down an incline, the employee attempted to make a left turn into a parking lot, struck a pothole in the road, and the forklift began to tip over to the right. The employee attempted to jump clear of the forklift, but was struck and killed as the forklift fell.
- *Struck by forklift:* The victim was assigned as the scrap dumpster forklift operator and was in route to a dumpster located in the remote southeast section of the outside material storage area. The victim was utilizing a forklift rated at 4,500 pounds. A metal dump hopper, equipped with a manual dump release handle, was attached to the forks of the forklift. The hopper was filled with scrap shingles. The victim positioned the load above the north side of the dumpster. He dismounted from the right side of the forklift, closest to the north wall of the dumpster, and tripped over the dump handle of the hopper. Before he dismounted, he failed to set the parking brake. As the load suddenly dropped, apparently the forklift jerked, causing the transmission, low on fluid, to slip into drive, and the right rear side of the forklift to travel toward the dumpster, pinning the victim against north wall of the dumpster. A crushing chest injury resulted. The primary cause of the accident was that the employee failed to set the parking brake before dismounting the powered forklift.
- *Struck by load toppling from forklift:* A longshoreman was crushed when he was struck by a toppling load of fiberboard. This cargo had just been off-loaded from a ship and was on the dock awaiting transfer by forklift to an adjacent warehouse. The forklift operator intended to pick up a stack of three crates. The width of the crates had changed from previous loads to more narrow gauges. The forklift operator did not realize he was dealing with a more narrow cargo, which allowed his forks to extend beyond the intended cargo's base. The forks extended some 10 inches under the base of an adjacent stack of three crates, which was some 31 inches wide. When the operator raised his forks he not only picked up his intended load, but also caused the adjacent stack of crates to topple onto the nearby longshoreman.
- *Fall from forks:* Two employees were riding the load, which was tied onto the forks of a forklift. The load was being lifted additionally with the aid of a crane. The men were standing on the load, as it was lifted about 23 feet in the air, above packed dirt. The load shifted and slipped off the forks, propelling the two men off the load. One man was seriously injured, and the other died of his injuries.

- *Struck by forklift:* Operator was driving a forklift forward with a load on the forks, which obstructed his view. The operator did not see the employee walking by and struck her.
- *Forklift tipover:* An employee was driving an unloaded forklift down a ramp with a 13 percent slope when the forklift started to tip over. The operator attempted to jump clear and the rollover protection of the forklift landed on him and killed him. The employee was not wearing the supplied seatbelt.
- *Struck by forklift:* The operator of a sit-down forklift (forklift #1) was in the process of delivering a pump to the drum/bleach line, unaware he was being followed by the operator of a stand-up forklift (forklift #2). The operator of forklift #1 received a page to turn off a valve, in route to deliver the pump. Parking his forklift next to three pallets of materials without lowering the forks, he went to answer the page. The distance between forklift #1 and forklift #2 was less than the required three truck lengths. In addition, there was insufficient passage in the aisle way and the presence of water leaking from a steam pipe in the area. Having nowhere to maneuver and little traction because of the wet floor, forklift #2 collided with the parked forklift #1. The right fork of forklift #1 stabbed into the left leg of the operator of forklift #2. The operator of the forklift #2 was pronounced dead upon arrival at the hospital.

General Operating Procedures for Forklifts

The general operating procedures outlined below are all safety related, affecting the PIT operator, the pedestrian or the load being transported. While some of these procedures may appear to be common sense, they should all be thoroughly discussed to enhance overall safety.

- If at any time a forklift is found to be in need of repair, defective or in any way unsafe, the forklift must be taken out of service until it has been restored to a safe operating condition.
- All repairs must be made by authorized personnel.
- Manufacturer's operating instructions must be understood by the operator.
- Operation of the controls must be explained and their functions demonstrated.
- Load capacity information must be explained. A forklift must never be used to lift a load beyond its capability.
- Fuel tanks must not be filled while the engine is running. Fuel spillage must be avoided.
- Any spillage of oil or fuel must be carefully washed away or evaporated. The fuel tank cap must be replaced before the engine is restarted.
- A forklift must not be operated if there is a leak in the fuel system. The leak must first be repaired.
- Seat belts are required to be worn while operating the forklift.
- The operator must always drive slowly enough to make a turn without tipping the forklift and to stop safely for pedestrians.
- Wet or slippery driving surfaces require slower than ordinary speeds.
- A forklift must be kept behind any other moving vehicle by at least three times the length of the forklift.
- The operator must not pass another vehicle at intersections, blind spots or other dangerous locations.
- The operator must slow down and sound the horn at cross aisles and other locations where vision is obstructed.
- The operator must watch for pedestrians, especially at intersections, passageways and doors leading from toilets, lunchrooms and offices.
- The operator must never drive directly toward anyone.
- Stunt driving and horseplay must not be permitted.
- A forklift may be used to elevate workers only if proper precautionary measures are taken:
 - A safety platform with guardrails should be firmly secured to the forks to keep the worker from falling.
 - The person being lifted should have some way of shutting off the power to the forklift in case of emergency.
 - Protection from falling objects should be provided in accordance with particular conditions.
- No one can be allowed to stand or pass under the lift portion of any forklift, whether loaded or empty, because injury may result from mechanical failure or falling objects.
- Before moving or stacking materials, the operator must survey the path of travel to avoid machinery, overhead obstructions, sprinkler systems, manufactured goods and other obstructions.
- Overloading will increase the risk that a forklift will tip over and reduce the ability to control it. Forklifts must not be overloaded.
- Loaders and/or operators must check the maximum load capacity on the forklift nameplate.
- Lifted loads must be neatly piled and cross-tied, if possible.
- To reduce the risk of tipping, the load must be centered on the lift forks.

- Carry the load low enough to avoid striking overhead obstructions, such as doorways, electrical conduits and sprinklers.
- Carry the load high enough to avoid raised or uneven surfaces.
- Do not raise or lower a load while the forklift is moving, lest the operator's attention is distracted from driving.
- Drive the forklift in reverse if bulky items obstruct the front view.
- Easy and gradual starts and stops help prevent loads from shifting.
- Exercise caution on inclines. Always drive with the load pointed uphill (whether ascending or descending).
- Be especially careful going downhill, so that the forklift can be brought to an emergency stop.
- Never load or park the forklift so as to block or obstruct fire aisles, fire equipment, or means of egress.
- Before boarding, the forklift operator must always wait at least 5 feet from the elevator gate until the elevator car is level with the floor. It does not matter whether the forklift is loaded or unloaded.
- The operator must only drive onto an elevator: (a) when authorized to do so and (b) when the elevator capacity allows it.
- After the elevator is level with the floor, center the forklift in the elevator.
- Once in the elevator, neutralize the controls, set the brakes, and shut off the power to the forklift.
- Motorized hand trucks must enter an elevator or other confined area with the load end forward.
- When loading highway trucks, properly secure the dockboard, then drive over it carefully and without an overload.
- Keep forklifts well back from the edge of loading docks and other open-sided floors.
- In order to safely board a highway truck with a forklift, set the brakes of the truck and chock the rear trailer wheels so that the truck will not move.

Note: As pertaining to OSHA standard (1910.178) during trailer loading/unloading operations, other positive mechanical means used to prevent truck/trailer movement may also be acceptable. OSHNC allows use of spring-loaded brake system and dock locks in lieu of chocking or blocks, since spring-loaded brakes or dock locks serve as acceptable means to secure trucks or trailers to loading docks.

29 CFR 1910.178(k)(1) requires wheel chocks to be placed under the rear wheels of highway trucks to prevent the trucks from rolling while they are boarded by powered industrial trucks; and 29 CFR 1910.178(m)(7) requires wheel blocks to be in place to prevent movement of trailers while loading or unloading.

Specifically, the opinion of the N.C. Department of Labor is that, spring-loaded brakes or dock locks are as safe as compliance with the standards and are an acceptable alternative to compliance with the standards provided the brake systems or dock locks are properly maintained, inspected and functionally checked to ensure effectiveness and reliability.

- Immediately upon uncoupling a semitrailer from its tractor, inspect the landing gear to ensure its ability to support the imposed load.
- Check the flooring of highway trucks, trailers and railroad cars for breaks and other signs of weakness before boarding with the forklift.
- If a semitrailer is not coupled to a tractor, fixed jacks may be needed to support the trailer and prevent its upending during loading or unloading.
- During loading or unloading operations, and before and while dockboards or bridge plates are in position, use wheel stops, hand brakes or the approved positive protection to prevent railroad cars from moving.
- A forklift must not be parked closer than 8 feet to a railroad track.
- When the operator must leave the forklift unattended, load engaging means must be fully lowered, controls must be neutralized, the power must be shut off, and the brakes must be set. An additional safety precaution is to remove the keys.

- When an operator is dismounted and is within 25 feet of the vehicle and is in view of the vehicle, the engine may be left running. The load engaging mechanism must be fully lowered, controls must be neutralized, and the brakes must be set.
- Wheels must be blocked if the forklift is parked on an incline.

Rollover Protection and Seat Belts?

OSHNC does not have a specific standard that requires the use or installation of seat belts; however, General Statute 95-129 (the General Duty Clause) requires employers to protect employees from serious and recognized hazards. Recognition of the hazard of powered industrial truck tipover and the need for the use an operator restraint system is evidenced by certain requirements for powered industrial trucks at ASME B56.1-1993—Safety Standard for Low Lift and High Lift Trucks. This standard requires that powered industrial trucks manufactured after 1992 must have and require operators use a restraint device, system, or enclosure that is intended to assist the operator in reducing the risk of entrapment of the operator’s head and/or torso between the truck and ground in the event of a tipover. OSHNC would enforce ASME B56.1-1993 under the General Duty Clause.

When an employer has been notified by a powered industrial truck manufacturer or association of the hazard of lift truck overturn and made aware of an operator restraint system retrofit program, OSHNC may cite under the General Duty Clause if the employer has not taken advantage of the program.

Maintenance, Refueling and Charging of Forklifts

Maintenance

Forklift operator trainees should be taught to inspect their forklifts after each shift and to report any defects to maintenance personnel.

- Any forklift not in safe operating condition must be removed from service.
- All repairs must be made by authorized maintenance personnel.
- Maintenance personnel must be aware that repairs must not be made in Class I, II and III locations (see 29 CFR 1910.399(a)).

Refueling

The forklift operator-training program should teach trainees to observe the following rules relative to the refueling of forklifts:

- Do not smoke at or near the refueling station.
- Do shut off the forklift engine when refueling.
- Do not restart gasoline or diesel-powered forklifts after refueling until all spilled fuel has evaporated, been wiped up or washed away, and until the fuel tank cap is back in place.
- Do check the LPG tank for damage from dents or gouges.
- Do inspect the quick-disconnect coupling for damage, deterioration, and damaged or missing flexible seals.
- Do inspect the valves and fittings of the LPG tank for damage and ensure that the relief valve points are in the direction specified by the manufacturer.
- Do wear gloves, long sleeves and a face shield when changing LPG tanks. Escaping gas is painfully cold to the skin.

Changing and Charging Storage Batteries

Many people do not know that batteries and battery acid can be dangerous. Forklift operators should be taught to observe these rules:

- Battery charging installation areas are designated as battery charging installation areas.

- Always wear appropriate impervious gauntlet gloves and eye and face protection when filling battery cells.
- Battery charging areas must be provided with operable emergency flushing facilities and with adequate ventilation for the dispersal of fumes that batteries produce during charging.
- “NO SMOKING” signs must be posted in battery charging areas. But whether the sign is there or not, do not smoke.
- Add battery acid to water. Do not add water to battery acid.
- A carboy tilter or siphon must be provided for handling electrolyte.
- The forklift must be properly positioned and the brake must be applied before an attempt is made to change or charge the batteries.
- The vent caps must be inspected to ensure that they are not plugged. To avoid electrolyte spray, the vent caps must be in position before the battery is charged.
- Tools and other metallic objects must be kept away from the top of uncovered batteries.
- So that heat may dissipate, the battery cover or compartment cover must be left open during the charging of batteries.

Procedures for Starting a Forklift

Teach forklift operator trainees to start a forklift in the following safe manner. Secure the seat belt; apply the foot brake; place the direction selector lever in NEUTRAL; turn the ignition key to ON until the engine starts; check for visibility both in front and behind before engaging the forklift gear. The forklift is now ready to operate.

Traveling, Loading, Transporting Loads and Maneuvering, and Unloading With a Forklift

Traveling

If forklift operators are to work safely and are to minimize costs to their employer, they should be trained to:

- Be knowledgeable about plant traffic patterns and conditions.
- Maintain a safe following distance (three forklift lengths or three seconds) behind other traffic.
- Keep a vehicle under control so that it can be stopped safely when floors are slippery, wet or uneven.
- Avoid running over loose materials and slippery areas in order to avoid:
 - Injury to the driver’s back
 - Loss of control of the forklift
 - Injury to the driver from being struck by the steering wheel or by a lever
 - Spilling the load
 - Turning the forklift over on its side.
- Secure the dockboard or bridge plates before crossing them with the forklift and travel over them slowly and carefully.
- Maintain adequate overhead clearance from lights, sprinklers, heaters, pipes, overhead tracks and doorways.
- Report or correct stacks of materials that are leaning, so that they will not collapse, whether under their own weight or when struck by an object.
- Steer the forklift only with smooth motions in order to prevent loss of control and the tipping of the load.
- Check the rear clearance of the forklift before maneuvering near pedestrians or near other vehicles.

Loading

The instructor of the forklift operator training program should teach trainees never to exceed the rated load capacity of the forklift and:

- When handling any load, space the forks so that the load weight is evenly distributed.

- Only attempt to handle stable or safely arranged loads.
- Approach each load slowly and carefully, with the mast in a vertical position until the load touches the carriage.
- Tilt the mast backwards slightly, then lift the load.
- Do not lift a load higher than necessary for safe traveling (2 to 6 inches floor clearance).

Transporting Loads and Maneuvering

Forklift operator trainees should be taught to respect the following rules when transporting loads and maneuvering their vehicles:

- Always look in the direction of travel.
- Always travel with the load as low as possible while maintaining good floor clearance. The mast should be angled slightly back. Keeping the load low helps maintain the stability of the forklift.
- Never lift or lower loads while traveling. Changing the load height while traveling with the forklift can affect the stability of the forklift and possibly interfere with forward vision.
- Railroad tracks should be crossed at a slight angle unless a long load is being carried across the forks.
- Allow for the rear swing (counterweight) when turning into narrow aisles.
- Slow down and sound the horn at cross-aisles, sharp curves, ramps, dips, blind corners, and on wet slippery or rough floors.
- In congested areas or when vision is obstructed, keep the forklift at a slow speed and watch for obstructions and pedestrians.
- Always operate on inclines with the load uphill go up inclines in forward gear and go back down in reverse.
- Protect against accidents or damage by making sure that the forklift and load weights do not exceed floor limits and that the raised mast or overhead guard clears all overhead obstacles, lights, pipes, sprinklers, heaters, overhead tracks and doorways.
- Prevent loss of control by turning the steering wheel only with smooth, controlled motions.
- Normally, starts and stops should not be sudden because they place unnecessary stress on the forklift.
- If the forklift is unattended and if the forklift is not within the operator's view, or if the forklift is more than 25 feet away, the operator must do these things: fully lower the attachment, put the controls in neutral, shut the engine off, set the brakes, and put the wheel chocks in place. Turn off the LP gas cylinder. To prevent a tripping hazard, place the forks of a forklift under a pallet.

Unloading

The forklift can be unloaded safely by placing the load on the floor, maneuvering the forklift into position, tilting the mast forward to vertical position so the load will be level, lowering the load, and smoothly backing away without dragging.

Pallets loaded with cases and cartons should be stacked straight and square. The top tier should be staggered so as to "tie" the pallets into place.

Operator trainees should be taught to stack rolls or round objects tightly together and straight. Then the rolls must be held securely with wedges.

Forklift Classifications and Where Forklifts May Be Operated

If forklift operators are to work safely, it is imperative that trainees be able to identify features of the forklift they operate according to its classification. Trainees should also be able to describe where a forklift with a particular classification may be operated and where it may not be operated.

Other Important Considerations for Forklift Operator Training

Lighting

Operator trainees should be knowledgeable about the proper amount of light they need to operate their vehicles safely. Where general lighting is less than 2 lumens per square foot, auxiliary directional lighting must be provided on a forklift.

Noxious Gases and Fumes

Management has the responsibility to see that no employee is exposed to an injurious environment caused by one of its forklifts. Concentration levels of noxious gases (oxides of nitrogen, hydrocarbon pollutants and carbon monoxide) produced by a forklift powered by diesel fuel, LP gas or gasoline must not exceed the levels specified in Subpart Z of 29 CFR 1910.1000 of the North Carolina OSH Standards for General Industry. Questions concerning the degree of concentration of gases and fumes may be referred to the Division of Occupational Safety and Health of the N.C. Department of Labor. (See the inside back cover of this publication for the telephone numbers and addresses.)

Hazardous Materials and Areas for Hazardous Materials

With regard to hazardous materials and areas containing hazardous materials, at a minimum, instructors of forklift operators should instruct trainees about:

- The employer's written hazard communication program.
- How to identify the type of material being handled.
- How to read the label of a chemical container to determine the chemical's shock sensitivity, flammability, and emergency spill or leak procedures.
- Appropriate types of personal protective equipment that must be worn, which may include footwear, equipment to protect the face, hands and head, and a respirator.
 - If a respirator is to be used, the operator must be trained to use it properly.
- How to select and use an approved forklift in hazardous locations.
- Notifying the supervisor immediately upon determining any leaking or damaged containers of chemicals. (Areas containing spills and leaks of hazardous materials must be isolated with ropes or similar devices.)

Safety Tips

Forklift operators can protect their well-being and the safety of others by remembering these safety tips:

- Only operate a forklift if you are authorized to do so.
- Become familiar with the features and functions of each forklift you operate.
- Give your forklift a thorough operational check each shift.
- Only use approved forklifts in classified locations where fire hazards exist.
- Do not allow a pedestrian to pass under the forks or attachment of your forklift.
- Assume the responsibility for keeping your forklift under control at all times.
- Know your travel routes that there is overhead clearance, that the bridge plates are secure, that the floor in the warehouse and trailer is of sufficient strength.
- Do not allow anyone to ride on your forklift as a passenger.
- Enforce the rule against stunt driving and horseplay.
- Protect your arms, legs and other parts of your body by keeping them within the forklift and overhead guard area.
- Obey the rule against eating or drinking while driving, so that your full attention can be on your work.
- Pick up a load only when you are sure it is stable.

- Know and do not exceed the rated load capacity of your forklift.
- Be responsible for your forklift—never leave it unattended.
- Protect yourself by observing the “NO SMOKING” rule at refueling and recharging stations.
- Protect others by driving with the forks low and by parking with the forks on the ground.
- Only allow authorized personnel to perform maintenance on your forklift.
- On ramps, drive in reverse when carrying a load down inclines, and look in the direction of travel when going up inclines.
- Make sure the forks of your forklift are not used as an elevator, unless you are using a safety platform designed to hold people.
- Satisfy yourself that the forklift you drive is equipped with these safety devices:
 - Backup alarm
 - Rearview mirror
 - High visibility color (with the rear of the forklift striped with paint or reflective tape)
 - Fire extinguisher
 - Adequate and readily accessible emergency shutdown (deadman seat brake)
 - Rollover protection and seat belts
 - Guards for air, hydraulic or fuel lines (from heat and abrasive objects)
 - Guards or shields for exhaust stack and service platform
 - Special tires (for comfort, traction)
- Immediately report to your supervisor accidents involving injury to an employee or damage to buildings and equipment.
- Stop your forklift’s engine before filling the fuel tank.
- Use convex mirrors at blind corners to watch for pedestrians.

Stability of Powered Industrial Trucks (PITs)

The stability of the powered industrial truck, loaded or unloaded, is critical to its safe operation. Therefore, the trainer will want to include a review of the basic principles of stability in the forklift operator training program.

A-1. Definitions

The following definitions help to explain the principle of stability:

- *Center of Gravity* is a point on an object at which all of the object’s weight can be considered to be concentrated.
- *Counterweight* is the weight that is a part of the truck’s basic structure that is used to offset the load’s weight and to maximize the vehicle’s resistance to tipping over.
- *Fulcrum* is the truck’s axis of rotation when it tips over.
- *Grade* is a surface’s slope that is usually measured as the number of feet of rise or fall over a 100-foot horizontal distance (measured as a percent).
- *Lateral stability* is a truck’s resistance to tipping over sideways.
- *Line of action* is an imaginary line through an object’s center of gravity.
- *Load center* is the horizontal distance from the load’s edge (or the fork’s or other attachment’s vertical face) to the line of action through the load’s center of gravity.
- *Longitudinal stability* is the truck’s resistance to overturning forward or rearward.
- *Moment* is the product of the object’s weight times the distance from a fixed point. In the case of a powered industrial truck, the distance is measured from the point that the truck will tip over to the object’s line of action. The distance is always measured perpendicular to the line of action.

- *Track* is the distance between wheels on the vehicle's same axle.
- *Wheelbase* is the distance between the centerline of the vehicle's front and rear wheels.

A-2. General

- Stability determination for a powered industrial truck depends on a few basic principles. There are many factors that contribute to a vehicle's stability:
 - Vehicle wheelbase
 - Track
 - Height
 - The load's weight distribution
 - The vehicle's counterweight location (if so equipped)
- The *stability triangle*, used in most stability discussions, demonstrates stability simply.

A-3. Basic Principles

- Determining whether an object is stable is dependent on the object's moment at one end of a system being greater than, equal to or smaller than the object's moment at the system's other end. This is the same principle on which a see-saw works. If the product of the load and distance from the fulcrum (moment) is equal to the moment at the device's other end, the device is balanced and will not move. However, if there is a greater moment at the device's one end, the device will try to move downward at the end with the greater moment.
- Longitudinal stability of a counterbalanced powered industrial truck depends on the vehicle's moment and the load's moment. In other words, if the mathematics product of the load moment (the distance from the front wheels, the point about which the vehicle would tip over) to the load's center of gravity times the load's weight is less than the vehicle's moment, the system is balanced and will not tip forward. However, if the load-moment is greater than the vehicle-moment, the greater load-moment will force the truck to tip forward.

A-4. The Stability Triangle

- Almost all counterbalanced powered industrial trucks have a three-point suspension system; that is, the vehicle is supported at three points. The truck's steer axle is attached to the truck by a pivot pin in the axle's center. When the points are connected with imaginary lines, this three-point support forms a triangle called the stability triangle.

Figure 1 depicts the stability triangle.

Figure 1.

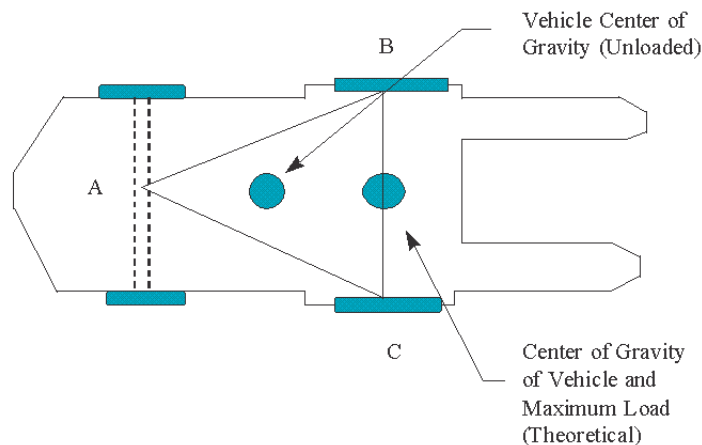

Notes:

- When the vehicle is loaded, the combined center of gravity (CG) shifts toward line B-C. Theoretically, the maximum load will result in the CG at the line B-C. In actual practice, the combined CG should never be at line B-C.
- The addition of additional counterweight will cause the truck CG to shift toward point A and result in a truck that is less stable laterally.
- When the vehicle's line of action, or load center, falls within the stability triangle, the vehicle is stable and will not tip over. However, when the vehicle's line of action or the vehicle/load combination falls outside the stability triangle, the vehicle is unstable and may tip over. **See figure 2.**

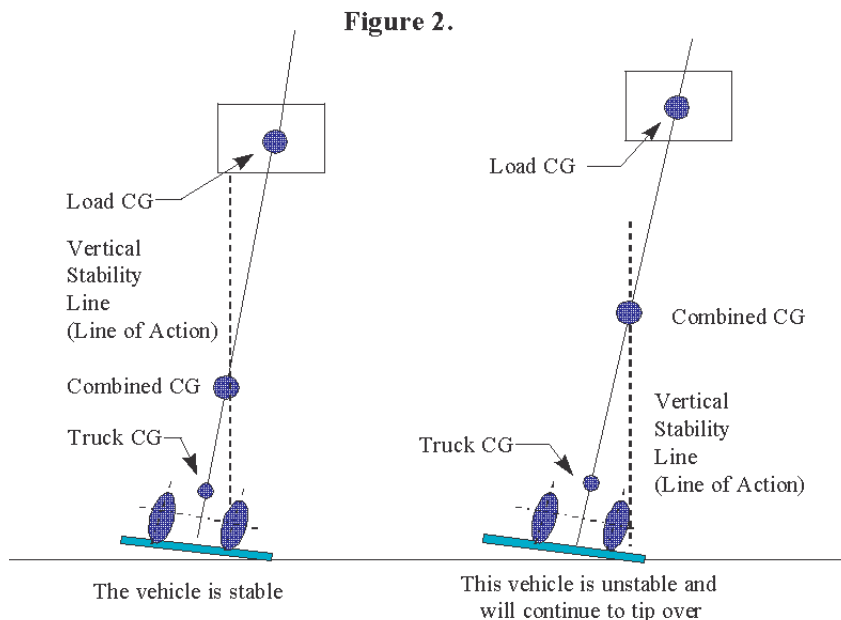

A-5. Longitudinal Stability

- The axis of rotation when a truck tips forward is the front wheels' points of contact with the pavement. When a powered industrial truck tips forward, the truck will rotate about this line. When a truck is stable, the vehicle's moment must exceed the load's moment. As long as the vehicle's moment is equal to or exceeds the load's moment, the vehicle will not tip over. On the other hand, if the load's moment slightly exceeds the vehicle's moment, the truck will begin to tip forward, thereby causing loss of steering control. If the load's moment greatly exceeds the vehicle's moment, the truck will tip forward.
- To determine the maximum safer load-moment, the truck manufacturer normally rates the truck at a maximum load at a given distance from the front face of the forks. The specified distance from the front face of the forks to the line of action of the load is commonly called a load center. Trucks with a 30,000 pounds or less capacity are normally rated at a given load weight at a 24-inch load center. For trucks of greater than 30,000 pounds capacity, the load center is normally rated at 36- or 48-inch load center distance. **To safely operate the vehicle, the operator should always check the data plate to determine the maximum allowable weight at the rated load center.**
- Although the true load-moment distance is measured from the front wheels, this distance is greater than the distance from the front face of the forks. Calculation of the maximum allowable load-moment using the load-center distance always provides a lower load-moment than the truck was designed to handle. When handling unusual loads, such as those that are larger than 48 inches long (the center of gravity is greater than 24 inches) or an offset center of gravity, etc., a maximum allowable load moment should be calculated and used to determine whether a load can be safely handled.
- For example, if an operator is operating a 3,000 pound capacity truck (with a 24-inch load center), the maximum allowable load moment is 72,000 inch pounds (3,000 times 24). If a probable load is 60 inches long (30-inch load center), then the maximum that this load can weigh is 2,400 pounds (72,000 divided by 30).

A-6. Lateral Stability

- The vehicle's lateral stability is determined by the lines of action's position (a vertical line that passes through the combined vehicle's and load's center of gravity) relative to the stability triangle. When the vehicle is not loaded, the truck's center of gravity location is the only factor to be considered in determining the truck's stability. As long as the line of action of the combined vehicle's and load's center of gravity falls within the stability triangle, the truck is stable and will not tip over. However, if the line of action falls outside the stability triangle, the truck is not stable and may tip over.
- Factors that affect the vehicle's lateral stability include the load's placement on the truck, the height of the load above the surface on which the vehicle is operating, and the vehicle's degree of lean.

A-7 Dynamic Stability

- The dynamic forces that result when the vehicle and load are put into motion must also be considered. The weight's transfer and the resultant shift in the center of gravity due to the dynamic forces created when the machine is moving, braking, cornering, lifting, tilting and lowering loads, etc., are important stability considerations.
- When determining whether a load can be safely handled, the operator should exercise extra caution when handling loads that cause the vehicle to approach its maximum design characteristics. For example, if an operator must handle a maximum weight load, the load should be carried at the lowest practical height, the truck should be accelerated slowly and evenly, and forks should be tilted forward cautiously. However, no precise rules can be formulated to cover all of these eventualities.

Sample Daily Checklists for Powered Industrial Trucks

Sample Generic Checklist for Powered Industrial Trucks

The checklists are intended to assist in providing training on OSHA's revised powered industrial truck operator standards. OSHA wishes to acknowledge the UAW-Ford National Joint Committee on Health and Safety for granting permission to use the checklists and related graphics.

Overhead Guard—Are there broken welds, missing bolts or damaged areas?

Hydraulic Cylinders—Is there leakage or damage on the lift, tilt or attachment functions of the cylinders?

Mast Assembly—Are there broken welds, cracked or bent areas, or worn or missing stops?

Lift Chains and Rollers

- Is there wear or damage or kinks, signs of rust, or any sign that lubrication is required?
- Is there squeaking?
- Are they cracked or bent, worn, or mismatched?
- Is there excessive oil or water on the forks?

Tires—What do the tires look like?

- Are there large cuts that go around the circumference of the tire?
- Are there large pieces of rubber missing or separated from the rim?
- Are there missing lugs?
- Is there bond separation that may cause slippage?

Battery Check

- Are the cell caps and terminal covers in place?
- Are the cables missing insulation?

Hydraulic Fluid—Check level.

Gauges—Are they all properly working?

Steering

- Is there excessive free play?
- If power steering, is the pump working?

Brakes

- If pedal goes all the way to the floor when you apply the service brake, that is the first indicator that the brakes are bad. Brakes should work in reverse, also.
- Does the parking brake work? The truck should not be capable of movement when the parking brake is engaged.

Lights—If equipped with lights, are they working properly?

Horn—Does the horn work?

Safety Seat—If the truck is equipped with a safety seat, is it working?

Load Handling Attachments

- Is there hesitation when hoisting or lowering the forks, when using the forward or backward tilt, or the lateral travel on the side shift?
- Is there excessive oil on the cylinders?

Propane Tank—Is the tank guard bracket properly positioned and locked down?

Propane Hose

- Is it damaged? It should not be frayed, pinched, kinked or bound in any way.
- Is the connector threaded on squarely and tightly?

Propane Odor—If you detect the presence of propane gas odor, turn off the tank valve and report the problem.

Engine Oil—Check levels.

Engine Coolant

- Visually check the level. Note: Never remove the radiator cap to check the coolant level when the engine is running or while the engine is hot. Stand to the side and turn your face away. Always use a glove or rag to protect your hand.

Transmission Fluid—Check levels.

Windshield Wipers—Do they work properly?

Seat Belts—Do they work?

Safety Door (found on stand up rider models)—Is it in place?

Safety Switch (found on stand up riding tow tractors)—Is it working?

Hand guards (found on stand up riding tow tractors, walking pallet trucks, walking transtackers)—Are they in place?

Tow Hook

- Does it engage and release smoothly?
- Does the safety catch work properly?

Control Lever—Does the lever operate properly?

Safety Interlock (found on order pickers)—If the gate is open, does the vehicle run?

Gripper Jaws (found on order pickers)—Do the jaws open and close quickly and smoothly?

Work Platform (found on order pickers)—Does the platform raise and lower smoothly?

Sample Daily Inspection Checklists

Each type of powered industrial truck is unique, and checklists pertinent to each type of vehicle should be modified accordingly. It is recommended that the manufacturer’s instructions on vehicle maintenance and owner’s and operator’s responsibilities also be consulted. Your workplace may have a variety of trucks that are being operated. They may include the following types of vehicles:

- Electric forklift trucks
- Propane forklift trucks
- Yard forklift trucks
- Electric transtacker
- Riding grip tow
- Stand-up riding tow tractor
- Walking pallet truck
- Walking transtacker
- Tow tractors
- Industrial tractors
- Reach trucks
- Order pickers

You may choose to use a checklist for each type of industrial truck you have in your workplace or compile one that can be used for any type of truck. Below are some sample checklists for various types of trucks, as well as a generic list that can be modified to suit your workplace needs.

Electric Forklift Truck

Key OFF Procedures

- The vehicle inspection
 - Overhead guard
 - Hydraulic cylinders
 - Mast assembly
 - Lift chains and rollers

- Forks
- Tires
- Examine the battery
- Check the hydraulic fluid level

Key ON Procedures

- Check the gauges
 - Hour meter
 - Battery discharge indicator
- Test the standard equipment
 - Steering
 - Brakes
 - Front, tail and brake lights
 - Horn
 - Safety seat (if equipped)
- Check the operation of load-handling attachments

Propane Forklift Truck

Key OFF Procedures

- The vehicle inspection
 - Overhead guard
 - Hydraulic cylinders
 - Mast assembly
 - Lift chains and rollers
 - Forks
 - Tires
 - LPG tank and locator pin
 - LPG tank hose
 - Gas gauge
- Check the engine oil level
- Examine the battery
- Inspect the hydraulic fluid level
- Check the engine coolant level

Key ON Procedures

- Test the front, tail and brake lights

Engine Running Procedures

- Check the gauges
 - Oil pressure indicator lamp
 - Ammeter indicator lamp
 - Hour meter
 - Water temperature gauge
- Test the standard equipment
 - Steering
 - Brakes
 - Horn
 - Safety seat (if equipped)
- Check the operation of load-handling attachments
- Check the transmission fluid level

Yard Forklift Truck

Key OFF Procedures

- The vehicle inspection
 - Overhead guard
 - Hydraulic cylinders
 - Mast assembly
 - Lift chains and rollers
 - Forks
 - Tires
 - LPG tank and locator pin
 - LPG tank hose
 - Gas gauge
- Check the engine oil level
- Examine the battery
- Inspect the hydraulic fluid level
- Check the engine coolant level

Key ON Procedures

- Test the standard equipment
 - Front, tail and brake lights
 - Fuel gauge (if diesel)
 - Windshield wiper
 - Heater

Engine Running Procedures

- Check the gauges
 - Oil pressure indicator lamp
 - Ammeter indicator lamp
 - Ammeter
 - Hour meter
 - Water temperature gauge
- Test the standard equipment
 - Steering
 - Brakes
 - Horn
 - Safety seat (if equipped)
- Check the operation of load-handling attachments
- Check the transmission fluid level

Electric Transtacker

Key OFF Procedures

- The vehicle inspection
 - Overhead guard
 - Hydraulic cylinders
 - Mast assembly
 - Lift chains and rollers
 - Forks
 - Tires
 - Battery cables
 - Safety door

Key ON Procedures

- Check the gauges
 - Battery discharge indicator
 - Hour meter

- Test the standard equipment
 - Steering
 - Brakes
 - Lights
 - Horn
- Test the control lever
- Check the operation of load-handling attachments

Riding Grip Tow

- The vehicle inspection
 - Lines and hoses
 - Battery
 - Safety switch
 - Hand guards
- The operations inspection
 - Test the brakes
 - Check the drive operations
 - Test the horn
 - Check the grip coupling

Stand-up Riding Tow Tractor

- The vehicle inspection
 - Lines and hoses
 - Battery
 - Safety switch
 - Hand guards
- The operations inspection
 - Test the brakes
 - Check the drive operations
 - Test the horn
 - Check the tow hook and safety catch

Walking Pallet Truck

- The vehicle inspection
 - Forks
 - Battery
 - Hand guards
- The operations inspection
 - Check the drive operations
 - Test the brakes
 - Check the horn
 - Inspect the load-handling attachment operations

Walking Transtacker

- The vehicle inspection
 - Forks
 - Battery
 - Hand guards
- The operations inspection
 - Check the drive operations
 - Test the brakes
 - Check the horn
 - Inspect the load-handling attachment operations

Indoor Propane Tow Tractor

Key OFF Procedures

- The vehicle inspection
 - Fluid leakage
 - Tires
 - Tow hook
 - Windshield (if equipped)
 - Overhead guard (if equipped)
 - LPG tank and locator pin
 - LPG tank hose
 - Gas gauge
- Check the engine oil level
- Check the engine coolant level
- Examine the battery

Key ON Procedures

- Test the front, tail and brake lights
- Check the gauges
 - Oil pressure gauge
 - Ammeter
 - Water temperature gauge
 - Hour meter

Engine Running Procedures

- Inspect the standard equipment
 - Steering
 - Brakes
 - Horn
 - Safety seat (if equipped)
- Check the transmission fluid level

Industrial Tractors

Key OFF Procedures

- The vehicle inspection
 - Windshield
 - Tires
 - Three-point hitch assembly
- Engine oil
- Engine coolant

Key ON Procedures

- Check gauges
 - Oil and battery lights
 - Temperature
 - Hour meter
- Standard equipment
 - Steering
 - Front, tail and brake lights
 - Horn

Engine Running Procedures

- Standard equipment
 - Windshield wiper
 - Brakes
 - Hoist operation

Reach Truck

Key OFF Procedures

- The vehicle inspection
 - Overhead guard
 - Hydraulic cylinders
 - Mast assembly
 - Lift chains and rollers
 - Forks
 - Tires
 - Battery cables
 - Safety door
 - Hydraulic fluid

Key ON Procedures

- Check the gauges
 - Battery discharge indicator
 - Hour meter
- Test the standard equipment
 - Steering
 - Brakes
 - Lights
 - Horn
- Test the control lever
- Check the operation of load-handling attachments

Order Picker

Key OFF Procedures

- The vehicle inspection
 - Hoist lines, cables and chains
 - Hour meter
 - Tires
 - Battery cables
 - Limiting device

Key ON Procedures

- Check the battery discharge indicator
- Test the standard equipment
 - Safety interlock
 - Steering
 - Brakes
 - Lights
 - Horn
- Check the accessories
 - Gripper jaws
 - Work platform

NOTE: These checklists are intended to assist in providing training on OSHA's revised powered industrial truck operator standards, part of which includes vehicle inspection and maintenance. They are not a substitute for any of the provisions of the Occupational Safety and Health Act of 1970, or for any standards issued by the U.S. Department of Labor's Occupational Safety and Health Administration. Please note that these lists serve only as a guide and may not be totally inclusive. OSHA wishes to acknowledge the UAW-Ford National Joint Committee on Health and Safety for granting permission to use the checklists and related graphics.

Sample Performance Test for Forklift Operators

Employee _____ Date _____ Time _____ a.m./p.m.

1. Shows familiarity with truck controls.
2. Gave proper signals when turning.
3. Slowed down at intersections.
4. Sounded horn at intersections.
5. Obeyed signs.
6. Kept a clear view of direction of travel.
7. Turned corners correctly—was aware of rear end swing.
8. Yielded to pedestrians.
9. Drove under control and within proper traffic aisles.
10. Approached load properly.
11. Lifted load properly.
12. Maneuvered properly.
13. Traveled with load at proper height.
14. Lowered load smoothly/slowly.
15. Stops smoothly/completely.
16. Load balanced properly.
17. Forks under load all the way.
18. Carried parts/stock in approved containers.
19. Checked bridgeplates/ramps.
20. Placed loads within marked area.
21. Stacked loads evenly and neatly.
22. Drove backward when required.
23. Checked load weights.
24. Placed forks on the floor when parked, controls neutralized, brake on set, power off.
25. Followed proper instructions for maintenance—checked both at beginning and end.

Total

Rating

Evaluator _____ **Date** _____

Note: This sample test was developed by the State of Michigan Department of Consumer and Industry Services, Safety Education and Training Division.

29 CFR 1910.178

Powered Industrial Trucks

1910.178 Powered industrial trucks.

(a) **General requirements.** (1) This section contains safety requirements relating to fire protection, design, maintenance, and use of fork trucks, tractors, platform lift trucks, motorized hand trucks, and other specialized industrial trucks powered by electric motors or internal combustion engines. This section does not apply to compressed air or nonflammable compressed gas-operated industrial trucks, or to farm vehicles, or to vehicles intended primarily for earth moving or over-the-road hauling.

(2) All new powered industrial trucks acquired and used by an employer after the effective date specified in paragraph (b) of 1910.182 shall meet the design and construction requirements for powered industrial trucks established in the “American National Standard for Powered Industrial Trucks, Part II, ANSI B56.1-1969”, which is incorporated by reference as specified in Sec. 1910.6, except for vehicles intended primarily for earth moving or over-the-road hauling.

(3) Approved trucks shall bear a label or some other identifying mark indicating approval by the testing laboratory. See paragraph (a)(7) of this section and paragraph 405 of “American National Standard for Powered Industrial Trucks, Part II, ANSI B56.1-1969”, which is incorporated by reference in paragraph (a)(2) of this section and which provides that if the powered industrial truck is accepted by a nationally recognized testing laboratory it should be so marked.

(4) Modifications and additions, which affect capacity and safe operation, shall not be performed by the customer or user without manufacturers’ prior written approval. Capacity, operation, and maintenance instruction plates, tags, or decals shall be changed accordingly.

(5) If the truck is equipped with front-end attachments other than factory installed attachments, the user shall request that the truck be marked to identify the attachments and show the approximate weight of the truck and attachment combination at maximum elevation with load laterally centered.

(6) The user shall see that all nameplates and markings are in place and are maintained in a legible condition.

(7) As used in this section, the term, “approved truck” or “approved industrial truck” means a truck that is listed

or approved for fire safety purposes for the intended use by a nationally recognized testing laboratory, using nationally recognized testing standards. Refer to 1910.155(c)(3)(iv)(A) for definition of nationally recognized testing laboratory.

(b) **Designations.** For the purpose of this standard there are eleven different designations of industrial trucks or tractors as follows: D, DS, DY, E, ES, EE, EX, G, GS, LP, and LPS.

(1) The D designated units are units similar to the G units except that they are diesel engine powered instead of gasoline engine powered.

(2) The DS designated units are diesel-powered units that are provided with additional safeguards to the exhaust, fuel and electrical systems. They may be used in some locations where a D unit may not be considered suitable.

(3) The DY designated units are diesel-powered units that have all the safeguards of the DS units and in addition do not have any electrical equipment including the ignition and are equipped with temperature limitation features.

(4) The E designated units are electrically powered units that have minimum acceptable safeguards against inherent fire hazards.

(5) The ES designated units are electrically powered units that, in addition to all of the requirements for the E units, are provided with additional safeguards to the electrical system to prevent emission of hazardous sparks and to limit surface temperatures. They may be used in some locations where the use of an E unit may not be considered suitable.

(6) The EE designated units are electrically powered units that have, in addition to all of the requirements for the E and ES units, the electric motors and all other electrical equipment completely enclosed. In certain locations the EE unit may be used where the use of an E and ES unit may not be considered suitable.

(7) The EX designated units are electrically powered units that differ from the E, ES, or EE units in that the electrical fittings and equipment are so designed, constructed and assembled that the units may be used in certain atmospheres containing flammable vapors or dusts.

(8) The G designated units are gasoline-powered units having minimum acceptable safeguards against inherent fire hazards.

(9) The GS designated units are gasoline-powered units that are provided with additional safeguards to the exhaust, fuel, and electrical systems. They may be used in some locations where the use of a G unit may not be considered suitable.

(10) The LP designated unit is similar to the G unit except that liquefied petroleum gas is used for fuel instead of gasoline.

(11) The LPS designated units are liquefied petroleum gas powered units that are provided with additional safeguards to the exhaust, fuel, and electrical systems. They may be used in some locations where the use of an LP unit may not be considered suitable.

(12) The atmosphere or location shall have been classified as to whether it is hazardous or non-hazardous prior to the consideration of industrial trucks being used therein and the type of industrial truck required shall be as provided in paragraph (d) of this section for such location.

(c) **Designated locations.** (1) The industrial trucks specified under subparagraph (2) of this paragraph are the minimum types required but industrial trucks having greater safeguards may be used if desired.

(2) For specific areas of use see Table N-1 that tabulates the information contained in this section. References are to the corresponding classification as used in subpart S of this part.

(i) Power-operated industrial trucks shall not be used in atmospheres containing hazardous concentration of acetylene, butadiene, ethylene oxide, hydrogen (or gases or vapors equivalent in hazard to hydrogen, such as manufactured gas), propylene oxide, acetaldehyde, cyclopropane, diethyl ether, ethylene, isoprene, or unsymmetrical dimethyl hydrazine (UDMH).

(ii) (a) Power-operated industrial trucks shall not be used in atmospheres containing hazardous concentrations of metal dust, including aluminum, magnesium, and their commercial alloys, other metals of similarly hazardous characteristics, or in atmospheres containing carbon black, coal or coke dust except approved power-operated industrial trucks designated as EX may be used in such atmospheres.

(b) In atmospheres where dust of magnesium, aluminum or aluminum bronze may be present, fuses, switches, motor controllers, and circuit breakers of trucks shall have enclosures specifically approved for such locations.

(iii) Only approved power-operated industrial trucks designated as EX may be used in atmospheres containing acetone, acrylonitrile, alcohol, ammonia, benzene, benzol, butane, ethylene dichloride, gasoline, hexane, lacquer solvent vapors, naphtha, natural gas, propane, propylene, styrene, vinyl acetate, vinyl chloride, or xylenes in quantities sufficient to produce explosive or ignitable mixtures and where such concentrations of these gases or vapors exist continuously, intermittently or periodically under normal operating conditions or may exist frequently because of repair, maintenance operations, leakage, breakdown or faulty operation of equipment.

(iv) Power-operated industrial trucks designated as DY, EE, or EX may be used in locations where volatile flammable liquids or flammable gases are handled, processed or used, but in which the hazardous liquids, vapors or gases will normally be confined within closed containers or closed systems from which they can escape only in case of accidental rupture or breakdown of such containers or systems, or in the case of abnormal operation of equipment; also in locations in which hazardous concentrations of gases or vapors are normally prevented by positive mechanical ventilation but which might become hazardous through failure or abnormal operation of the ventilating equipment; or in locations which are adjacent to Class I, Division 1 locations, and to which hazardous concentrations of gases or vapors might occasionally be communicated unless such communication is prevented by adequate positive-pressure ventilation from a source of clear air, and effective safeguards against ventilation failure are provided.

(v) In locations used for the storage of hazardous liquids in sealed containers or liquefied or compressed gases in containers, approved power-operated industrial trucks designated as DS, ES, GS, or LPS may be used. This classification includes locations where volatile flammable liquids or flammable gases or vapors are used, but which, would become hazardous only in case of an accident or of some unusual operating condition. The quantity of hazardous material that might escape in case of accident, the adequacy of ventilating equipment, the total area involved, and the record of the industry or business with respect to explosions or fires are all factors that should receive consideration in determining whether or not the DS or DY, ES, EE, GS, LPS designated truck possesses sufficient safeguards for the location. Piping without valves, checks, meters and similar devices would not ordinarily be deemed to introduce a hazardous condition even though used for hazardous liquids or gases. Locations used for the storage of hazardous liquids or of liquefied or compressed gases in sealed containers would not normally be considered hazardous unless subject to other hazardous conditions also.

TABLE N-1.—SUMMARY TABLE ON USE OF INDUSTRIAL TRUCKS IN VARIOUS LOCATIONS

Classes	Unclassified		Class I locations				Class II locations			Class III locations							
Description of classes....	Locations not possessing atmospheres as described in other columns.		Locations in which flammable gases or vapors are, or may be, present in the air in quantities sufficient to produce explosive or ignitable mixtures.				Locations which are hazardous because of the presence of combustible dust.			Locations where easily ignitable fibers or flyings are present but not likely to be in suspension in quantities sufficient to produce ignitable mixtures.							
Groups in classes	None	A	B	C	D	E	F	G	None								
Examples of locations or atmospheres in classes and groups.	Piers and wharves inside and outside general storage, general industrial or commercial properties.	Acetylene	Hydrogen	Ethyl ether	Gasoline Naphtha Alcohols Acetone Lacquer solvent Benzene	Metal dust	Carbon black coal dust, coke dust	Grain dust, flour dust, starch dust, organic dust	Baled waste, cocoa fiber, cotton, excelsior, hemp, istle, jute, kapok, oakum, sisal, Spanish moss, synthetic fibers, tow.l								
		1	2	1	2	1	2	1	2								
Divisions (nature of hazardous conditions)	None	Above condition exists continuously, intermittently, or periodically under normal operating conditions.	Above condition may occur accidentally as due to a puncture of a storage drum.	Explosive mixture may be present under normal operating conditions, or where failure of equipment may cause the condition to exist simultaneously with arcing or sparking of electrical equipment, or where dusts of an electrically conducting nature may be present.	Explosive mixture not normally present, but where deposits of dust may cause heat rise in electrical equipment, or where such deposits may be ignited by arcs or sparks from electrical equipment.	Locations in which easily ignitable fibers or materials producing combustible flyings are handled, manufactured, or used.	Locations in which easily ignitable fibers are stored or handled (except in the process of manufacture).										
Authorized uses of trucks by types in groups of classes and divisions																	
Groups in classes	None	A	B	C	D	A	B	C	D	E	F	G	E	F	G	None	None
Type of truck authorized:																	
Diesel:																	
Type D																	
Type DS										DS					DS		DS
Type DY										DY					DY		DY
Electric:																	
Type E																	E
Type ES										ES					ES		ES
Type EE										EE					EE		EE
Type EX						EX				EX	EX	EX			EX	EX	EX
Gasoline:																	
Type G																	
Type GS										GS					GS		GS
LP-Gas:																	
Type LP																	
Type LPS										LPS					LPS		LPS
Paragraph Ref in No 505	210.211	201 (a)	203 (a)	209 (a)	204 (a), (b)	202 (a)	205 (a)	209 (a)	206 (a), (b)	207 (a)	208 (a)						

**Trucks conforming to these types may also be used—see subdivision (c)(2)(x) and (c)(2)(xii) of this section

(vi) (a) Only approved power operated industrial trucks designated as EX shall be used in atmospheres in which combustible dust is or may be in suspension continuously, intermittently, or periodically under normal operating conditions, in quantities sufficient to produce explosive or ignitable mixtures, or where mechanical failure or abnormal operation of machinery or equipment might cause such mixtures to be produced.

(b) The EX classification usually includes the working areas of grain handling and storage plants, room containing grinders or pulverizers, cleaners, graders, scalpers, open conveyors or spouts, open bins or hoppers, mixers, or blenders, automatic or hopper scales, packing machinery, elevator heads and boots, stock distributors, dust and stock collectors (except all-metal collectors vented to the outside), and all similar dust producing machinery and equipment in grain processing plants, starch plants, sugar pulverizing plants, malting plants, hay grinding plants, and other occupancies of similar nature; coal pulverizing plants (except where the pulverizing equipment is essentially dust tight); all working areas where metal dusts and powders are produced, processed, handled, packed, or stored (except in tight containers); and other similar locations where combustible dust may, under normal operating conditions, be present in the air in quantities sufficient to produce explosive or ignitable mixtures.

(vii) Only approved power-operated industrial trucks designated as DY, EE, or EX shall be used in atmospheres in which combustible dust will not normally be in suspension in the air or will not be likely to be thrown into suspension by the normal operation of equipment or apparatus in quantities sufficient to produce explosive or ignitable mixtures but where deposits or accumulations of such dust may be ignited by arcs or sparks originating in the truck.

(viii) Only approved power-operated industrial trucks designated as DY, EE, or EX shall be used in locations which are hazardous because of the presence of easily ignitable fibers or flyings but in which such fibers or flyings are not likely to be in suspension in the air in quantities sufficient to produce ignitable mixtures.

(ix) Only approved power-operated industrial trucks designated as DS, DY, ES, EE, EX, GS, or LPS shall be used in locations where easily ignitable fibers are stored or handled, including outside storage, but are not being processed or manufactured. Industrial trucks designated as E, which have been previously used in these locations, may be continued in use.

(x) On piers and wharves handling general cargo, any approved power-operated industrial truck designated as Type D, E, G, or LP may be used, or trucks, which conform to the requirements for these types, may be used.

(xi) If storage warehouses and outside storage locations are hazardous only the approved power-operated industrial truck specified for such locations in this paragraph (c) (2) shall be used. If not classified as hazardous, any approved power-operated industrial truck designated as Type D, E, G, or LP may be used, or trucks which conform to the requirements for these types may be used.

(xii) If general industrial or commercial properties are hazardous, only approved power-operated industrial trucks specified for such locations in this paragraph (c) (2) shall be used. If not classified as hazardous, any approved power-operated industrial truck designated as Type D, E, G, or LP may be used, or trucks, which conform to the requirements of these types, may be used.

(d) **Converted industrial trucks.** Power-operated industrial trucks that have been originally approved for the use of gasoline for fuel, when converted to the use of liquefied petroleum gas fuel in accordance with paragraph (q) of this section, may be used in those locations where G, GS or LP, and LPS designated trucks have been specified in the preceding paragraphs.

(e) **Safety guards.** (1) High Lift Rider trucks shall be fitted with an overhead guard manufactured in accordance with paragraph (a) (2) of this section, unless operating conditions do not permit.

(2) If the type of load presents a hazard, the user shall equip fork trucks with a vertical load backrest extension manufactured in accordance with paragraph (a) (2) of this section.

(f) **Fuel handling and storage.** (1) The storage and handling of liquid fuels such as gasoline and diesel fuel shall be in accordance with NFPA Flammable and Combustible Liquids Code (NFPA No. 30-1969), which is incorporated by reference as specified in Sec. 1910.6.

(2) The storage and handling of liquefied petroleum gas fuel shall be in accordance with NFPA Storage and Handling of Liquefied Petroleum Gases (NFPA No. 58-1969), which is incorporated by reference as specified in Sec. 1910.6.

(g) **Changing and charging storage batteries.** (1) Battery charging installations shall be located in areas designated for that purpose.

(2) Facilities shall be provided for flushing and neutralizing spilled electrolyte, for fire protection, for protecting charging apparatus from damage by trucks, and for adequate ventilation for dispersal of fumes from gassing batteries.

(3) [Reserved]

(4) A conveyor, overhead hoist, or equivalent material handling equipment shall be provided for handling batteries.

(5) Reinstalled batteries shall be properly positioned and secured in the truck.

(6) A carboy tilter or siphon shall be provided for handling electrolyte.

(7) When charging batteries, acid shall be poured into water; water shall not be poured into acid.

(8) Trucks shall be properly positioned and brake applied before attempting to change or charge batteries.

(9) Care shall be taken to assure that vent caps are functioning. The battery (or compartment) cover(s) shall be open to dissipate heat.

(10) Smoking shall be prohibited in the charging area.

(11) Precautions shall be taken to prevent open flames, sparks, or electric arcs in battery charging areas.

(12) Tools and other metallic objects shall be kept away from the top of uncovered batteries.

(h) **Lighting for operating areas.** (1) [Reserved]

(2) Where general lighting is less than 2 lumens per square foot, auxiliary directional lighting shall be provided on the truck.

(i) **Control of noxious gases and fumes.** (1) Concentration levels of carbon monoxide gas created by powered industrial truck operations shall not exceed the levels specified in 1910.1000.

(j) **Dockboards (bridge plates).** See 1910.30(a).

(k) **Trucks and railroad cars.** (1) The brakes of highway trucks shall be set and wheel chocks placed under the rear wheels to prevent the trucks from rolling while they are boarded with powered industrial trucks.

(2) Wheel stops or other recognized positive protection shall be provided to prevent railroad cars from moving during loading or unloading operations.

(3) Fixed jacks may be necessary to support a semitrailer and prevent upending during the loading or unloading when the trailer is not coupled to a tractor.

(4) Positive protection shall be provided to prevent railroad cars from being moved while dockboards or bridge plates are in position.

(l) **Operator training.** (1) *Safe operation.* (i) The employer shall ensure that each powered industrial truck operator is competent to operate a powered industrial truck safely, as demonstrated by the successful completion of the training and evaluation specified in this paragraph (1).

(ii) Prior to permitting an employee to operate a powered industrial truck (except for training purposes), the

employer shall ensure that each operator has successfully completed the training required by this paragraph (1), except as permitted by paragraph (1)(5).

(2) *Training program implementation.* (i) Trainees may operate a powered industrial truck only:

(A) Under the direct supervision of persons who have the knowledge, training, and experience to train operators and evaluate their competence; and

(B) Where such operation does not endanger the trainee or other employees.

(ii) Training shall consist of a combination of formal instruction (e.g., lecture, discussion, interactive computer learning, video tape, written material), practical training (demonstrations performed by the trainer and practical exercises performed by the trainee), and evaluation of the operator's performance in the workplace.

(iii) All operator training and evaluation shall be conducted by persons who have the knowledge, training, and experience to train powered industrial truck operators and evaluate their competence.

(3) *Training program content.* Powered industrial truck operators shall receive initial training in the following topics, except in topics which the employer can demonstrate are not applicable to safe operation of the truck in the employer's workplace.

(i) Truck-related topics:

(A) Operating instructions, warnings, and precautions for the types of truck the operator will be authorized to operate;

(B) Differences between the truck and the automobile;

(C) Truck controls and instrumentation: where they are located, what they do, and how they work;

(D) Engine or motor operation;

(E) Steering and maneuvering;

(F) Visibility (including restrictions due to loading);

(G) Fork and attachment adaptation, operation, and use limitations;

(H) Vehicle capacity;

(I) Vehicle stability;

(J) Any vehicle inspection and maintenance that the operator will be required to perform;

(K) Refueling and/or charging and recharging of batteries;

(L) Operating limitations;

(M) Any other operating instructions, warnings, or precautions listed in the operator's manual for the types of vehicle that the employee is being trained to operate.

(ii) Workplace-related topics:

(A) Surface conditions where the vehicle will be operated;

(B) Composition of loads to be carried and load stability;

(C) Load manipulation, stacking, and unstacking;

(D) Pedestrian traffic in areas where the vehicle will be operated;

(E) Narrow aisles and other restricted places where the vehicle will be operated;

(F) Hazardous (classified) locations where the vehicle will be operated;

(G) Ramps and other sloped surfaces that could affect the vehicle's stability;

(H) Closed environments and other areas where insufficient ventilation or poor vehicle maintenance could cause a buildup of carbon monoxide or diesel exhaust;

(I) Other unique or potentially hazardous environmental conditions in the workplace that could affect safe operation.

(iii) The requirements of this section.

(4) *Refresher training and evaluation.* (i) Refresher training, including an evaluation of the effectiveness of that training, shall be conducted as required by paragraph (1)(4)(ii) to ensure that the operator has the knowledge and skills needed to operate the powered industrial truck safely.

(ii) Refresher training in relevant topics shall be provided to the operator when:

(A) The operator has been observed to operate the vehicle in an unsafe manner;

(B) The operator has been involved in an accident or near-miss incident;

(C) The operator has received an evaluation that reveals that the operator is not operating the truck safely;

(D) The operator is assigned to drive a different type of truck; or

(E) A condition in the workplace changes in a manner that could affect safe operation of the truck.

(iii) An evaluation of each powered industrial truck operator's performance shall be conducted at least once every three years.

(5) *Avoidance of duplicative training.* If an operator has previously received training in a topic specified in paragraph (1)(3) of this section, and such training is appropriate to the truck and working conditions encountered, additional training in that topic is not required if the operator has been evaluated and found competent to operate the truck safely.

(6) *Certification.* The employer shall certify that each operator has been trained and evaluated as required by this paragraph (1). The certification shall include the name of the operator, the date of the training, the date of the evaluation, and the identity of the person(s) performing the training or evaluation.

(7) *Dates.* The employer shall ensure that operators of powered industrial trucks are trained, as appropriate, by the dates shown in the following table.

If the employee was hired:	The initial training and evaluation of that employee must be completed:
Before December 1, 1999	By December 1, 1999.
After December 1, 1999	Before the employee is assigned to operate a powered industrial truck.

(8) Appendix A to this section provides non-mandatory guidance to assist employers in implementing this paragraph (1). This appendix does not add to, alter, or reduce the requirements of this section.

(m) *Truck operations.* (1) Trucks shall not be driven up to anyone standing in front of a bench or other fixed object.

(2) No person shall be allowed to stand or pass under the elevated portion of any truck, whether loaded or empty.

(3) Unauthorized personnel shall not be permitted to ride on powered industrial trucks. A safe place to ride shall be provided where riding of trucks is authorized.

(4) The employer shall prohibit arms or legs from being placed between the uprights of the mast or outside the running lines of the truck.

(5) (i) When a powered industrial truck is left unattended, load engaging means shall be fully lowered, controls shall be neutralized, power shall be shut off, and brakes set. Wheels shall be blocked if the truck is parked on an incline.

(ii) A powered industrial truck is unattended when the operator is 25 ft. or more away from the vehicle which remains in his view, or whenever the operator leaves the vehicle and it is not in his view.

(iii) When the operator of an industrial truck is dismounted and within 25 ft. of the truck still in his view,

the load engaging means shall be fully lowered, controls neutralized, and the brakes set to prevent movement.

(6) A safe distance shall be maintained from the edge of ramps or platforms while on any elevated dock, or platform or freight car. Trucks shall not be used for opening or closing freight doors.

(7) Brakes shall be set and wheel blocks shall be in place to prevent movement of trucks, trailers, or railroad cars while loading or unloading. Fixed jacks may be necessary to support a semitrailer during loading or unloading when the trailer is not coupled to a tractor. The flooring of trucks, trailers, and railroad cars shall be checked for breaks and weakness before they are driven onto.

(8) There shall be sufficient headroom under overhead installations, lights, pipes, sprinkler system, etc.

(9) An overhead guard shall be used as protection against falling objects. It should be noted that an overhead guard is intended to offer protection from the impact of small packages, boxes, bagged material, etc., representative of the job application, but not to withstand the impact of a falling capacity load.

(10) A load backrest extension shall be used whenever necessary to minimize the possibility of the load or part of it from falling rearward.

(11) Only approved industrial trucks shall be used in hazardous locations.

(12) [Removed and Reserved]

(13) [Reserved]

(14) Fire aisles, access to stairways, and fire equipment shall be kept clear.

(n) **Traveling.** (1) All traffic regulations shall be observed, including authorized plant speed limits. A safe distance shall be maintained approximately three truck lengths from the truck ahead, and the truck shall be kept under control at all times.

(2) The right of way shall be yielded to ambulances, fire trucks, or other vehicles in emergency situations.

(3) Other trucks traveling in the same direction at intersections, blind spots, or other dangerous locations shall not be passed.

(4) The driver shall be required to slow down and sound the horn at cross aisles and other locations where vision is obstructed. If the load being carried obstructs forward view, the driver shall be required to travel with the load trailing.

(5) Railroad tracks shall be crossed diagonally wherever possible. Parking closer than 8 feet from the center of railroad tracks is prohibited.

(6) The driver shall be required to look in the direction of, and keep a clear view of the path of travel.

(7) Grades shall be ascended or descended slowly.

(i) When ascending or descending grades in excess of 10 percent, loaded trucks shall be driven with the load upgrade.

(ii) [Reserved]

(iii) On all grades the load and load engaging means shall be tilted back if applicable, and raised only as far as necessary to clear the road surface.

(8) Under all travel conditions the truck shall be operated at a speed that will permit it to be brought to a stop in a safe manner.

(9) Stunt driving and horseplay shall not be permitted.

(10) The driver shall be required to slow down for wet and slippery floors.

(11) Dockboard or bridgeplates, shall be properly secured before they are driven over. Dockboard or bridgeplates shall be driven over carefully and slowly and their rated capacity never exceeded.

(12) Elevators shall be approached slowly, and then entered squarely after the elevator car is properly leveled. Once on the elevator, the controls shall be neutralized, power shut off, and the brakes set.

(13) Motorized hand trucks must enter elevator or other confined areas with load end forward.

(14) Running over loose objects on the roadway surface shall be avoided.

(15) While negotiating turns, speed shall be reduced to a safe level by means of turning the hand steering wheel in a smooth, sweeping motion. Except when maneuvering at a very low speed, the hand steering wheel shall be turned at a moderate, even rate.

(o) **Loading.** (1) Only stable or safely arranged loads shall be handled. Caution shall be exercised when handling off-center loads which cannot be centered.

(2) Only loads within the rated capacity of the truck shall be handled.

(3) The long or high (including multiple-tiered) loads which may affect capacity shall be adjusted.

(4) Trucks equipped with attachments shall be operated as partially loaded trucks when not handling a load.

(5) A load engaging means shall be placed under the load as far as possible; the mast shall be carefully tilted backward to stabilize the load.

(6) Extreme care shall be used when tilting the load forward or backward, particularly when high tiering. Tilting

forward with load engaging means elevated shall be prohibited except to pick up a load. An elevated load shall not be tilted forward except when the load is in a deposit position over a rack or stack. When stacking or tiering, only enough backward tilt to stabilize the load shall be used.

(p) **Operation of the truck.** (1) If at any time a powered industrial truck is found to be in need of repair, defective, or in any way unsafe, the truck shall be taken out of service until it has been restored to safe operating condition.

(2) Fuel tanks shall not be filled while the engine is running. Spillage shall be avoided.

(3) Spillage of oil or fuel shall be carefully washed away or completely evaporated and the fuel tank cap replaced before restarting engine.

(4) No truck shall be operated with a leak in the fuel system until the leak has been corrected.

(5) Open flames shall not be used for checking electrolyte level in storage batteries or gasoline level in fuel tanks.

(q) **Maintenance of industrial trucks.** (1) Any power-operated industrial truck not in safe operating condition shall be removed from service. All repairs shall be made by authorized personnel.

(2) No repairs shall be made in Class I, II, and III locations.

(3) Those repairs to the fuel and ignition systems of industrial trucks which involve fire hazards shall be conducted only in locations designated for such repairs.

(4) Trucks in need of repairs to the electrical system shall have the battery disconnected prior to such repairs.

(5) All parts of any such industrial truck requiring replacement shall be replaced only by parts equivalent as to safety with those used in the original design.

(6) Industrial trucks shall not be altered so that the relative positions of the various parts are different from what they were when originally received from the manufacturer, nor shall they be altered either by the addition of extra parts not provided by the manufacturer or by the elimination of any parts, except as provided in paragraph (q)(12) of this section. Additional counterweighing of fork trucks shall not be done unless approved by the truck manufacturer.

(7) Industrial trucks shall be examined before being placed in service, and shall not be placed in service if the examination shows any condition adversely affecting the safety of the vehicle. Such examination shall be made at least daily. Where industrial trucks are used on a round-the-clock basis, they shall be examined after each shift. Defects when found shall be immediately reported and corrected.

(8) Water mufflers shall be filled daily or as frequently as is necessary to prevent depletion of the supply of water below 75 percent of the filled capacity. Vehicles with mufflers having screens or other parts that may become clogged shall not be operated while such screens or parts are clogged. Any vehicle that emits hazardous sparks or flames from the exhaust system shall immediately be removed from service, and not returned to service until the cause for the emission of such sparks and flames has been eliminated.

(9) When the temperature of any part of any truck is found to be in excess of its normal operating temperature, thus creating a hazardous condition, the vehicle shall be removed from service and not returned to service until the cause for such overheating has been eliminated.

(10) Industrial trucks shall be kept in a clean condition, free of lint, excess oil, and grease. Noncombustible agents should be used for cleaning trucks. Low flash point (below 100 deg. F.) solvents shall not be used. High flash point (at or above 100 deg. F.) solvents may be used. Precautions regarding toxicity, ventilation, and fire hazard shall be consonant with the agent or solvent used.

(11) [Reserved]

(12) Industrial trucks originally approved for the use of gasoline for fuel may be converted to liquefied petroleum gas fuel provided the complete conversion results in a truck which embodies the features specified for LP or LPS designated trucks. Such conversion equipment shall be approved. The description of the component parts of this conversion system and the recommended method of installation on specific trucks are contained in the "Listed by Report."

[39 FR 23502, June 27, 1974, as amended at 40 FR 23073, May 28, 1975; 43 FR 49749, Oct. 24, 1978; 49 FR 5322, Feb. 10, 1984; 53 FR 12122, Apr. 12, 1988; 55 FR 32015, Aug. 6, 1990; 61 FR 9227, March 7, 1996; 63 FR 66270, Dec. 1, 1998; 68 FR 32368, June 2, 2003]

Safety and Health Topics: Powered Industrial Trucks

Each year, tens of thousands of forklift-related injuries occur in U.S. workplaces. Many employees are injured when lift trucks are inadvertently driven off loading docks or lifts fall between docks and an unsecured trailer. Employees are also struck by a lift truck or fall while on elevated pallets and tines. Most incidents also involve property damage, including damage to overhead sprinklers, racking, pipes, walls and machinery. Unfortunately, most employee injuries and property damage can be attributed to lack of safe operating procedures, lack of safety-rule enforcement, and insufficient or inadequate training.

The National Institute for Occupational Safety and Health (NIOSH) investigations of forklift-related deaths indicate that many workers and employers may not be aware of the risks of operating or working near forklifts. Many individuals are not following the procedures set forth in the OSHA standards, consensus standards or equipment manufacturer's guidelines. Additionally, within North Carolina, employers must comply with the state specific rules for general industry standards (13 NCAC 07F.0101) or construction standards (13 NCAC07.0201) as applicable for the requirements referenced in the N.C. Administrative Code (NCAC).

Generally, reducing the risk of forklift incidents requires comprehensive worker training, systematic traffic management, a safe work environment, a safe forklift and safe work practices. The primary OSHA standard is 29 CFR 1910.178, Powered Industrial Trucks. However, this standard incorporates by reference a number of other OSHA standards as well as industry standards describing truck design, approval and labeling:

- General Design and Construction Standards, 1910.178(a)(2)
 - All new powered industrial trucks acquired and used by an employer after the effective date specified in paragraph (b) of 1910.182 shall meet the design and construction requirements for powered industrial trucks established in the “American National Standard for Powered Industrial Trucks, Part II, ANSI B56.1-1969”, which is incorporated by reference as specified in Sec. 1910.6, except for vehicles intended primarily for earth moving or over-the-road hauling. [See ASME B56.1 for the current version.]
- Labeling, 1910.178(a)(3)
 - Approved trucks shall bear a label or some other identifying mark indicating approval by the testing laboratory. See paragraph (a)(7) of this section and paragraph 405 of “American National Standard for Powered Industrial Trucks, Part II, ANSI B56.1-1969”, which is incorporated by reference in paragraph (a)(2) of this section and which provides that if the powered industrial truck is accepted by a nationally recognized testing laboratory it should be so marked. [See ASME B56.1 for the current version.]
- Approved Truck, 1910.178(a)(7)
 - As used in this section, the term “approved truck” or “approved industrial truck” means a truck that is listed or approved for fire safety purposes for the intended use by a nationally recognized testing laboratory, using nationally recognized testing standards. Refer to 1910.155(c)(3)(iv)(A) for definition of nationally recognized testing laboratory. [See 1910.155(c)(3)(iv)(A) for the scope and application of the fire protection subpart.]
- Storage and Handling of Liquid Fuels, 1910.178(f)(1)
 - The storage and handling of liquid fuels such as gasoline and diesel fuel shall be in accordance with NFPA Flammable and Combustible Liquids Code (NFPA 30-1969), which is incorporated by reference as specified in Sec. 1910.6. [See NFPA 30 for the current version.]
- Storage and Handling of Liquid Petroleum Gas, 1910.178(f)(2)
 - The storage and handling of liquefied petroleum gas fuel shall be in accordance with NFPA Storage and Handling of Liquefied Petroleum Gases (NFPA No. 58-1969), which is incorporated by reference as specified in Sec. 1910.6. [See NFPA 58 for the current version.]
- Carbon Monoxide Levels, 1910.178(i)(1)
 - Concentration levels of carbon monoxide gas created by powered industrial truck operations shall not exceed the levels specified in 1910.1000. [See state specific requirements listed in 13 NCAC 07F.0101.]
- Dockboards, 1910.178(j)
 - Dockboards (bridge plates). See 1910.30(a).

- Hazardous Classified Locations
STD 1-11.6A—Disparity Between 29 CFR 1910.178(c)(2)(vii) and Table N-1, 29 CFR 1910.178(c)(2), OSHA Directive (Feb. 19, 1979)
 - NFPA No. 505-1969 is the source standard for 29 CFR 1910.178(b), (c) and (d). However, OSHA, by 29 CFR 1910.178(c)(2)(vii), chose not to permit these designated industrial trucks for use in all Class II, Division 2, locations. Their acronyms, nevertheless, were inadvertently left in the Table when the NFPA Table 1 became OSHA Table N-1. See NFPA 505 for the current version.

The specific OSHA requirements that apply to employers who use powered industrial trucks are separated into the following activities:

- Loading and Unloading
- Working With Hazardous Materials
- Vehicle Maintenance

Voluntary standards help the government fulfill its mandate to ensure public safety and health and provide sound technical solutions to today's critical issues without creating additional cost and operations burdens. Organizations that develop industry consensus standards include:

- American Society of Mechanical Engineers (ASME)
- National Fire Protection Association (NFPA)
- International Organization for Standardization (ISO)
- American Society of Mechanical Engineers (ASME)

The following standards are available from the ASME site:

- ASME B56.1, Safety Standard for High Lift and Low Lift Trucks (1993 Revised 2000) 98 pages. This document defines the safety requirements relating to the elements of design, operation, and maintenance of low lift and high lift powered industrial trucks controlled by a riding or walking operator, and intended for use on compacted, improved surfaces.
- ASME B56.11.6, Evaluation of Visibility From Powered Industrial Trucks (1992 Reaffirmed 2000), 12 pages. This standard establishes the conditions, procedures, equipment and acceptability criteria for evaluating visibility from powered industrial trucks. It applies to internal combustion engine powered and electric high lift, counterbalanced, sit-down rider industrial trucks up to and including 10,000 kg. (22,000 lb.) capacity, inspection, testing, and acceptance, thereby fostering universal use of export pallets in international commerce with minimal restrictions.
- ASME 56.6, Safety Standards for Rough Terrain Forklifts (2002), 50 pages. This standard defines the safety requirements relating to the elements of design, operation and maintenance of rough terrain forklift trucks. These trucks are intended for operation on unimproved natural terrain as well as the disturbed terrain of construction sites.
- ASME 56.10, Safety Standard for Manually Propelled High Lift Industrial Trucks (1992, Reaffirmed 2000), 22 pages. This document defines the safety requirements relating to the elements of design, operation and maintenance of manually propelled high lift industrial trucks controlled by a walking operator, and intended for use on level, improved surfaces.
- ASME B56.11.3, Load Handling Symbols for Powered Industrial Trucks (1992, Reaffirmed 2000), 11 pages. This standard defines symbols to be used in identifying load handling controls for powered industrial trucks.
- ASME B56.11.4, Hook-Type Forks and Fork Carriers for Powered Industrial Forklift Trucks (1992, Reaffirmed 2000), 9 pages. This document encompasses standards relative to hook-type fork carriers and the attaching elements of fork arms and load handling attachments for forklift trucks, in relation to manufacturers' rated capacities of trucks up to and including 11,000 kg. (24,000 lb.).
- ASME 56.11.7, Liquefied Petroleum Gas (LPG) Fuel Cylinders (Horizontal or Vertical) Mounting—Liquid Withdrawal—For Powered Industrial Trucks (1998), 12 pages.
- Powered Industrial Trucks: Symbols for Operator's Controls and Other Displays, 2001 (Identical to ISO 3287-

1999), 52 pages. This standard establishes symbols for use on operator controls and other displays on powered industrial trucks.

- B56 Interpretations, ISO (2003), 1 page. A series of PDF documents is available of interpretations of the following standards: B56.1 (2083 KB PDF, 59 pages), B56.5 (203 KB PDF, 8 pages), B56.6 (430 KB PDF, 13 pages), B56.8 (67 KB PDF, 3 pages), B56.9 (90 KB PDF, 3 pages), and B56.11 (36 KB PDF, 1 page).

National Fire Protection Association (NFPA)

- NFPA 505, Fire Safety Standard for Powered Industrial Trucks Including Type Designations, Areas of Use, Conversions, Maintenance and Operations, 2002 Edition. NFPA 505 identifies industrial truck types for use in hazardous (classified) locations, truck conversions, maintenance and operation requirements for industrial trucks powered by electric motors or internal combustion engines.
- NFPA 58, Liquefied Petroleum Gas Code, 2001 Edition. NFPA 58 identifies new requirements for all large tank installations, for operating and maintenance procedures, and for fire safety analyses.
- NFPA 30, Flammable and Combustible Liquids Code, 1996 Edition. NFPA 30 identifies how to properly use, contain and store flammable and combustible liquids.
- Fire Protection Guide to Hazardous Materials, (2001), 664 pages. This all-in-one book contains much of the data contained in NFPA documents derived from hundreds of reference sources. The Guide contains the following:
 - NFPA 49, Hazardous Chemicals Data, which identifies 325 chemicals in MSDS format.
 - NFPA 325, Fire Hazard Properties of Flammable Liquids, Gases, and Volatile Solids, which identifies over 1300 chemicals in tabular format listing various data.
 - NFPA 491, Guide for Hazardous Chemical Reactions, which identifies 3,550 dangerous mixtures documented from real-life incidents
 - NFPA 497, Recommended Practice for the Classification of Flammable Liquids, Gases, or Vapors and of Hazardous (Classified) Locations for Electrical Installations in Chemical Process Areas, which identifies parameters to determine the degree and extent of hazardous locations for liquids, gases and vapors including NEC groups.
 - NFPA 704, Standard System for the Identification of the Hazards of Materials for Emergency Response, which provides a readily recognized, easily understood system, the “Diamond Hazard,” for identifying specific hazards and their severity. Hazards are identified using spatial, visual, and numerical methods to describe in simple terms the relative hazards of a material. It addresses the health, flammability, instability and related hazards that may be presented as short-term, acute exposures that are most likely to occur as a result of fire, spill or similar emergency.
 - Data extracted from:
 - NFPA 77, Recommended Practice on Static Electricity, which identifies combustibility parameters and static electric characteristics.
 - NFPA 499, Recommended Practice for the Classification of Combustible Dusts and of Hazardous (Classified) Locations for Electrical Installations in Chemical Process Areas, which identifies parameters to determine the degree and extent of hazardous locations for dusts, including NEC groups.
 - NFPA 430, Code for the Storage of Liquid and Solid Oxidizers, which identifies oxidizer classifications for 90 chemicals.
- See the NFPA Web site, for a complete listing of its standards.

International Organization for Standardization (ISO)

- The International Standards Organization (ISO) has extensive standards for powered industrial trucks including:
 - Industrial Trucks, ISO Classification 53, Materials Handling Equipment, 53.060, Industrial Trucks Including Forklift Trucks, Sliding Platforms, etc.
 - ISO 509:1996, Pallet trucks—Principal dimensions (available in English only)
 - ISO 938:1975, Hand-operated stillage trucks—Principal dimensions
 - ISO 1044:1993, Industrial trucks—Lead-acid traction batteries for electric trucks—Preferred voltages
 - ISO 1074:1991, Counterbalanced fork-lift trucks—Stability tests
 - ISO 1756:1975, Industrial trucks—Dimensions of stillages—Connection gauge

- ISO 2163:1975, Industrial trucks—Wheels and castors—Vocabulary
- ISO 2184-1:1972, Industrial castors—Dimensions of top plates—Part 1: Oblong top-plates with 4 bolt holes
- ISO 2328:1993, Fork-lift trucks—Hook-on type fork arms and fork arm carriages—Mounting dimensions
- ISO 2330:2002, Fork-lift trucks—Fork arms—Technical characteristics and testing
- ISO 2331:1974, Fork lift trucks—Hook-on type fork arms—Vocabulary
- ISO 3184:1998, Reach and straddle fork-lift trucks—Stability tests
- ISO 3184:1998/Cor 1:2000, Reach and straddle fork-lift trucks—Stability tests
- ISO 3287:1999, Powered industrial trucks—Symbols for operator controls and other displays. (Replaces ASME B56.11.3-1992. The standard is ASME 3287-2001 revised (Aug. 31, 2001) and can also be ordered from ASME.
- ISO 3691:1980/ Amd 1:1983, Powered industrial trucks—Safety code
- ISO 3739-3:1995, Industrial tyres and rims—Part 3: Rims
- ISO 5053:1987, Powered industrial trucks—Terminology
- ISO 5057:1993, Industrial trucks—Inspection and repair of fork arms in service on fork-lift trucks
- ISO 5766:1990, Pallet stackers and high-lift platform trucks—Stability tests
- ISO 5767:1992/Amd 1:1999, Industrial trucks operating in special condition of stacking with mast tilted forward—Additional stability test
- ISO 6055:1997, High-lift rider trucks—Overhead guards—Specification and testing
- ISO 6292:1996, Powered industrial trucks and tractors—Brake performance and component strength
- ISO 8379:1998, Rough terrain trucks—Stability tests
- ISO 10525:1997, Counterbalanced trucks handling freight containers of 6 m (20 ft) length and above—Additional stability tests
- ISO 10658:1996, Industrial trucks operating in special conditions of stacking with load laterally displaced by powered devices—Additional stability test
- ISO 13562-1:2000, Industrial variable-reach trucks—Part 1: Stability tests
- ISO 13562-2:2001, Industrial variable-reach trucks—Part 2: Additional stability tests for trucks handling freight containers of 6 m length and above
- ISO 13563-1:2001, Single side loading fork-lift trucks—Part 1: Stability tests
- ISO 13563-2:2001, Single side loading fork-lift trucks—Part 2: Additional stability tests for trucks handling freight containers of 6 m length and above
- ISO 15794:2001, Bi-directional and multi-directional fork-lift trucks—Stability tests
- ISO 15870:2000, Powered industrial trucks—Safety signs and hazard pictorials—General principles
- ISO 15871:2000, Industrial trucks—Specifications for indicator lights for container handling and grappler arm operations
- Industrial Trucks, Technical Committee (TC)110. International Standards Organization (ISO):
 - ISO TC 110/SC1, Subcommittee 1: General Terminology
 - ISO TC 110/SC2, Subcommittee 2: Safety of Powered Industrial Trucks

Safety requirements related to:

- Design and construction
- Testing and inspection methods
- Operation and maintenance
- Principal dimensions to facilitate interchangeability where essential to the interest of users and manufacturers
- ISO TC 110/SC3, Subcommittee 3: Industrial Wheels and Castors

The following industry guides are available from the N.C. Department of Labor's Division of Occupational Safety and Health:

- #1. A Guide to Safety in Confined Spaces*
- #2. A Guide to Procedures of the Safety and Health Review Board of North Carolina*
- #3. A Guide to Machine Safeguarding*
- #4. A Guide to OSHA in North Carolina*
- #5. A Guide for Persons Employed in Cotton Dust Environments*
- #6. A Guide to Lead Exposure in the Construction Industry*
- #7. A Guide to Bloodborne Pathogens in the Workplace*
- #8. A Guide to Voluntary Training and Training Requirements in OSHA Standards*
- #9. A Guide to Ergonomics*
- #10. A Guide to Farm Safety and Health*
- #11. A Guide to Radio Frequency Hazards With Electric Detonators*
- #12. A Guide to Forklift Operator Training*
- #13. A Guide to the Safe Storage of Explosive Materials*
- #14. A Guide to the OSHA Excavations Standard*
- #15. A Guide to Developing and Maintaining an Effective Hearing Conservation Program*
- #17. A Guide to Asbestos for Industry*
- #18. A Guide to Electrical Safety*
- #19. A Guide to Occupational Exposure to Wood and Wood Dust*
- #20. A Guide to Crane Safety*
- #21. A Guide to School Safety and Health*
- #23. A Guide to Working With Electricity*
- #25. A Guide to Personal Protective Equipment*
- #26. A Guide to Manual Materials Handling and Back Safety*
- #27. A Guide to the Control of Hazardous Energy (Lockout/Tagout)*
- #28. A Guide to Eye Wash and Safety Shower Facilities*
- #29. A Guide to Safety and Health in Feed and Grain Mills*
- #30. A Guide to Working With Corrosive Substances*
- #31. A Guide to Formaldehyde*
- #32. A Guide to Fall Prevention in Industry*
- #33. A Guide to Office Safety and Health*
- #34. A Guide to Safety and Health in the Poultry Industry*
- #35. A Guide to Preventing Heat Stress*
- #36. A Guide to the Safe Use of Escalators and Elevators*
- #37. A Guide to Boilers and Pressure Vessels*
- #38. A Guide to Safe Scaffolding*
- #39. A Guide to Safety in the Textile Industry*
- #40. A Guide to Emergency Action Planning*
- #41. A Guide to OSHA for Small Businesses in North Carolina*

Occupational Safety and Health (OSH)

Sources of Information

You may call 1-800-NC-LABOR (1-800-625-2267) to reach any division of the N.C. Department of Labor; or visit the NCDOL home page on the World Wide Web, Internet Web site address: <http://www.nclabor.com>.

N.C. Division of Occupational Safety and Health

Mailing Address:
1101 Mail Service Center
Raleigh, NC 27699-1101
Local Telephone: (919) 807-2900 Fax: (919) 807-2856

Physical Location:
111 Hillsborough St.
(Old Revenue Building, 3rd Floor)

For information concerning education, training and interpretations of occupational safety and health standards contact:

Bureau of Education, Training and Technical Assistance

Mailing Address:
1101 Mail Service Center
Raleigh, NC 27699-1101
Telephone: (919) 807-2875 Fax: (919) 807-2876

Physical Location:
111 Hillsborough St.
(Old Revenue Building, 4th Floor)

For information concerning occupational safety and health consultative services and safety awards programs contact:

Bureau of Consultative Services

Mailing Address:
1101 Mail Service Center
Raleigh, NC 27699-1101
Telephone: (919) 807-2899 Fax: (919) 807-2902

Physical Location:
111 Hillsborough St.
(Old Revenue Building, 3rd Floor)

For information concerning migrant housing inspections and other related activities contact:

Agricultural Safety and Health Bureau

Mailing Address:
1101 Mail Service Center
Raleigh, NC 27699-1101
Telephone: (919) 807-2923 Fax: (919) 807-2924

Physical Location:
111 Hillsborough St.
(Old Revenue Building, 2nd Floor)

For information concerning occupational safety and health compliance contact:

Safety and Health Compliance District Offices

Raleigh District Office (313 Chapanoke Road, Raleigh, NC 27603)
Telephone: Safety (919) 662-4597 Fax: (919) 662-4709
Health (919) 662-4711

Asheville District Office (204 Charlotte Highway, Suite B, Asheville, NC 28803-8681)
Telephone: (828) 299-8232 Fax: (828) 299-8266

Charlotte District Office (901 Blairhill Road, Suite 200, Charlotte, NC 28217-1578)
Telephone: Safety (704) 342-6163 Fax: (704) 342-5919

Winston-Salem District Office (4964 University Parkway, Suite 202, Winston-Salem, NC 27106-2809)
Telephone: Safety (336) 776-4420 Fax: (336) 767-3989
Health (336) 776-4420 Fax: (336) 767-3989

Wilmington District Office (1200 N. 23rd St., Suite 205, Wilmington, NC 28405-1824)
Telephone: (910) 251-2678 Fax: (910) 251-2654

To make an OSHA Complaint, **OSH Complaint Desk:** (919) 807-2796

For statistical information concerning program activities contact:

Planning, Statistics and Information Management

Mailing Address:
1101 Mail Service Center
Raleigh, NC 27699-1101
Telephone: (919) 807-2950 Fax: (919) 807-2951

Physical Location:
111 Hillsborough St.
(Old Revenue Building, 2nd Floor)

For information about books, periodicals, vertical files, videos, films, audio/slide sets and computer databases contact:

N.C. Department of Labor Library

Mailing Address:
1101 Mail Service Center
Raleigh, NC 27699-1101
Telephone: (919) 807-2848 Fax: (919) 807-2849

Physical Location:
111 Hillsborough St.
(Old Revenue Building, 5th Floor)

N.C. Department of Labor (Other than OSH)

1101 Mail Service Center
Raleigh, NC 27699-1101
Telephone: (919) 733-7166 Fax: (919) 733-6197